

The Instruction Set of the TANGO Controller



In der Murch 15
35579 Wetzlar
Germany
Tel.: +49/6441/9116-0
www.marzhauser.com



1. Table of Contents

1.	Table of Contents	2
2.	Introduction.....	7
3.	Hint for controller initialization.....	9
4.	Instruction Syntax Description.....	16
5.	Error Numbers and their possible Root Cause	16
6.	Controller Informations.....	17
6.1.	version (Read detailed Version information)	17
6.2.	det (Read detailed Configuration)	18
6.3.	detext (Read Extended detailed Configuration)	18
6.4.	readsn (Read Serial Number)	19
6.5.	ver (Read default Version Number)	19
6.6.	iver (Read internal Version Number)	19
6.7.	uptime (Read Controller Up Time)	20
6.8.	temp (Read Case Temperature)	20
6.9.	maxaxis (Read number of available Axes)	20
6.10.	maxcur (Read Maximum Motor Current)	20
6.11.	etspresent (Read ETS Detect State)	21
6.12.	stagesn (Read Connected Devices Serial Number)	22
7.	Communication Interface Settings.....	23
7.1.	baud (Baud Rate)	23
7.2.	cts (Enable/Disable RS232 Hardware Handshake)	23
8.	System Instructions	24
8.1.	save (Save Parameters)	24
8.2.	restore (Restore Saved Parameters)	24
8.3.	reset (Force a Software Reset).....	25
8.4.	pa (Enable or Disable the Power Amplifiers)	25
8.5.	ipreter (Select Instruction Set)	26
9.	Operating Modes	27
9.1.	Extended Mode.....	27
9.1.1	extmode (Switch to Extended Mode)	27
9.2.	Scan Mode	28
9.2.1	scanmode (Switch to Scan Mode).....	28
9.2.2	scanvel (Scanmode Vector Velocity).....	28
9.3.	ModuloMode	29
9.3.1	modulomode (Define Linear or Turntable Modes)	29
10.	Controller States and Error Messages.....	30
10.1.	autostatus (Set Autostatus to required behavior).....	30
10.2.	statusaxis (Read State of Axis).....	31
10.3.	corrst (Read Position Correction State)	31
10.4.	status (Read the Controller Error State)	32
10.5.	err (Read Error Number).....	32
10.6.	help (Read Error Number with Description String).....	32
10.7.	service (Print Service Information to Terminal)	33
10.8.	pci (Is PCI Bus).....	33
10.9.	isvel (Read Actual Velocities)	33
10.10.	maxpos (Maximum Position)	34
11.	General Adjustments.....	35



11.1.	dim (Unit for Positions and Velocities)	35
11.2.	pitch (Spindle Pitch).....	36
11.3.	gear (Gear Ratio).....	36
11.4.	motorsteps (Motor Steps Per Revolution).....	37
11.5.	accel (Acceleration)	38
11.6.	accelfunc (Acceleration Ramp Function)	38
11.7.	stopaccel (Emergency Stop Deceleration).....	39
11.8.	vel (Velocity)	40
11.9.	velfac (Velocity Factor)	41
11.10.	sevel (Secure Velocity)	41
11.11.	cur (Motor Current).....	42
11.12.	reduction (Motor Current Reduction Factor)	43
11.13.	curdelay (Delay for Current Reduction)	43
11.14.	ecomove (EcoMove Current Level)	44
11.15.	axis (Enable, Disable, Switch Off Axis).....	45
11.16.	axisdir (Axis Direction).....	45
11.17.	motortable (Motor Correction Table).....	46
11.18.	usteps (Microstep Resolution)	46
11.19.	resolution (Position Number Format).....	47
11.20.	backlash (Mechanical Backlash Compensation)	47
11.21.	lock (Select Parameters to Lock).....	48
11.22.	lockaxis (Apply the Parameter Lock to Axes)	48
11.23.	lockstate (Read all internal Lock States)	49
11.24.	stout (Select Status Signal Output).....	49
11.25.	noled (Select Status Signal Output).....	50
11.26.	updelay (Power Up Delay).....	50
12.	Limit Switch Instructions (Hardware and Software)	51
12.1.	lim (Software Limits)	51
12.2.	limctr (Enable or Disable Limit Control)	51
12.3.	nosetlimit (Do not set limits by cal/rm)	52
12.4.	swtyp (Type of Limit Switch)	52
12.5.	swpol (Polarity of Limit Switch)	53
12.6.	swdir (swap assignment of cal and rm switch).....	53
12.7.	swact (enable or disable limit switches).....	54
12.8.	readsw (Read Status of Limit Switches)	55
12.9.	swin (Read Limit Switch Input Level)	55
12.10.	statuslimit (Cal / Rm / Lim Status)	56
13.	Calibration and Range Measure Instructions.....	57
13.1.	cal (Perform Calibration to lower Limit Switch)	57
13.2.	rm (Perform Range Measure to upper Limit Switch).....	58
13.3.	vrm (Virtual Range Measure).....	59
13.4.	calmode (Closed Loop/Calibration Behavior)	60
13.5.	carequired (Calibration Required).....	60
13.6.	caltimeout (Calibration Timeout)	61
13.7.	caliboffset (Calibration Offset).....	62
13.8.	rmoffset (Range Measure Position Offset).....	62
13.9.	caldir (Calibration Direction)	62
13.10.	calbspeed (Calibration Speed for Retraction).....	63
13.11.	calrefspeed (Reference Signal Calibration Speed).....	63
13.12.	encrefvel (Encoder Ref Signal Calibration Velocity)	64
13.13.	refdir (Direction for Searching Reference Signal)	64



13.14.	calpos (Calibration Position).....	65
13.15.	calvel (Calibration Velocities for CAL Instruction).....	66
13.16.	rmvel (Range Measure Velocities for RM Instruction)	67
13.17.	autopitch (Measure Pitch after CAL Instruction)	67
14.	Move Instructions	68
14.1.	moa (Move Absolute).....	69
14.2.	mor (Move Relative)	69
14.3.	m (Move Relative Shortcut)	70
14.4.	distance (Distance for m).....	70
14.5.	moc (Move to Center)	70
14.6.	go (Go To Position).....	71
14.7.	speed (Speed Move)	72
14.8.	a (Abort the Current Move)	72
14.9.	delay (Set the Delay Time for Consecutive Moves).....	73
14.10.	pause (Set the Pause after Position Reached).....	73
14.11.	pos (Read or Set Position)	74
14.12.	posclr (Clear Position Offset).....	74
14.13.	zero (Set Internal Position to Zero).....	75
14.14.	clearpos (Set Internal Position to Zero)	75
15.	HDI Instructions (Joystick, Trackball, ERGODRIVE)	76
15.1.	joy (Generally Enable/Disable HDI)	76
15.2.	joydir (Joystick Direction or Assign Joystick per axis).....	77
15.3.	joychangeaxis (Change Joystick X and Y Axis).....	77
15.4.	joywindow (Joystick Window)	78
15.5.	joyvel (Joystick Velocity).....	78
15.6.	joyspeed (Joystick Speed Presets for BPZ Device).....	78
15.7.	keymode (Joystick Key Mode).....	79
15.8.	keyspeed (Joystick Key Speed Presets).....	80
15.9.	joycurve (Joystick Characteristic)	80
15.10.	key (Read HDI Device Key State)	81
15.11.	keyl (Read HDI Device Latched Key State).....	81
15.12.	hwfactor (Coaxial-/ERGODRIVE Transmission Factor).....	82
15.13.	hwfactorb (Alternate Coaxial-/ERGODRIVE Factor).....	82
15.14.	hwfilter (Coaxial-/ERGODRIVE Noise Filter)	82
15.15.	tbfactor (Trackball Factor)	83
15.16.	zwheel (Is Multi-function Wheel Available)	84
15.17.	zwtravel (Multi-function Wheel Travel per Revolution).....	84
15.18.	zwaxis (Multi-function Wheel Axis)	85
15.19.	zwfactor (Multi-function Wheel Factor)	85
15.20.	tvrjoy (Pulse and Direction Joystick Functionality).....	86
15.21.	tvrjoyf (Pulse and Direction Joystick Factor).....	86
15.22.	hdi (Read HDI ID).....	87
15.23.	hdimode (HDI Mode Options).....	88
15.24.	configaxsel (Joystick Axis Select Option)	89
16.	Joystick Function Key Assignments	90
17.	Digital and Analogue I/O	91
17.1.	digin (I/O1 Digital Inputs)	91
17.2.	digout (I/O1 Digital Outputs)	91
17.3.	diginpol (I/O1 Digital Input Ploarity)	92
17.4.	digintyp (I/O1 Digital Input Type)	92
17.5.	digoutpreset (I/O1 Digital Output Presets).....	93



17.6.	edigin (Multi I/O Digital Inputs).....	94
17.7.	edigout (Multi I/O Digital Outputs).....	94
17.8.	ediginpol (Multi I/O Digital Input Ploarity).....	95
17.9.	edigintyp (Multi I/O Digital Input Type).....	95
17.10.	edigoutpreset (Multi I/O Digital Output Presets).....	96
17.11.	adigin (AUX-I/O Digital Input).....	97
17.12.	adigout (AUX-I/O Digital Output).....	97
17.13.	anain (Analogue Input).....	98
17.14.	anaout (Analogue Output).....	99
17.15.	anamode (Analogue Output Mode).....	99
17.16.	stoppol (Mode and Polarity of Stop Input Signal).....	100
17.17.	stop (Release, Force or Check Stop Condition).....	101
17.18.	shutter (Shutter Out Signal of AUX-IO).....	101
17.19.	flash (Defined Pulse at AUX-IO Takt Out).....	102
18.	Encoder Instructions.....	103
18.1.	encmask (Encoder Mask).....	103
18.2.	enc (Encoder Active).....	104
18.3.	encperiod (Encoder Signal Period).....	104
18.4.	encdir (Encoder Counting Direction).....	105
18.5.	encvel (Encoder Auto-Ajust Velocity).....	105
18.6.	enctl (Encoder has TTL Signal).....	106
18.7.	encref (Use Encoder Reference Signal).....	106
18.8.	encnas (Use Encoder NAS Error Signal).....	107
18.9.	encrefstatus (Encoder REF Signal State).....	107
18.10.	encrefstatusl (Latched Encoder REF Signal State).....	107
18.11.	encnasstatus (Encoder NAS Error Signal State).....	108
18.12.	encerr (Encoder Error State).....	108
18.13.	encamp (Encoder Signal Amplitude).....	108
18.14.	encpos (Encoder Position).....	109
18.15.	hwcount (Hardware Counter).....	109
18.16.	clearhwcount (Clear Hardware Counter).....	109
19.	MR Encoder Instructions.....	110
19.1.	mra (MR Amplitude Correction Factor).....	110
19.2.	mro (MR Offset Correction Value).....	110
19.3.	mrp (MR Signal Peak-To-Peak Measuring Result).....	111
19.4.	mrt (MR Signal Level).....	111
20.	Closed Loop Instructions.....	112
20.1.	ctr (Control Enable).....	112
20.2.	ctrf (Control Factor).....	113
20.3.	ctrff (Extended Control Factor).....	113
20.4.	ctrc (Control Call).....	114
20.5.	ctrd (Control Target Window Delay).....	114
20.6.	ctrtr (Control Timeout).....	114
20.7.	twi (Target Window).....	115
20.8.	ctrsm (Control behavior outside Lock-in Range).....	115
20.9.	ctrs (Control Lock-in Range).....	116
20.10.	ctrstatus (Control Status).....	117
20.11.	ctrdiff (Control Position Difference).....	118
21.	Trigger Output Functionality (option).....	119
21.1.	trig (Trigger).....	119
21.2.	triga (Trigger Axis).....	119



- 21.3. trigm (Trigger Mode) 120
- 21.4. trigo (Trigger Output) 121
- 21.5. trigs (Trigger Signal Length) 122
- 21.6. trigd (Trigger Distance) 122
- 21.7. trigcomp (Trigger Compensation) 122
- 21.8. trigenc (Trigger on Encoder) 123
- 21.9. trigf (Trigger Frequency) 123
- 21.10. trigbdelay (Precise Trigger Delay for second output)..... 124
- 21.11. trigbwidth (Precise Signal Width for second output) 124
- 21.12. trigbf (Precise Trigger Frequency for second output) 124
- 21.13. trigcount (Trigger Counter) 125
- 21.14. trigger (Force Trigger Signal) 125
- 21.15. trigr (Set Trigger Range)..... 126
- 22. The Second Trigger Signal Output..... 127**
- 22.1. Introduction..... 127
- 22.2. Standard 1:1 128
- 22.3. Precise Width..... 129
- 22.4. Precise Delay..... 130
- 22.5. Precise Frequency 131
- 23. Snapshot -Trigger Input Functionality (option)..... 132**
- 23.1. sns (Snapshot enable/disable)..... 133
- 23.2. snsl (Snapshot Level / Polarity) 133
- 23.3. snsf (Snapshot Filter)..... 133
- 23.4. snsm (Snapshot Mode)..... 134
- 23.5. Snapshot Mode Description and Examples 135
- 23.6. snsc (Snapshot Counter) 136
- 23.7. snsi (Snapshot Index) 136
- 23.8. snsaxis (Snapshot Axis) 137
- 23.9. snsp (Snapshot Position) 138
- 23.10. snsa (Snapshot Array) 138
- 23.11. snse (Snapshot Event) 139
- 23.12. sns v (Snapshot Voltage) 139
- 23.13. prehome (Snapshot PreHome Position) 140
- 23.14. home (Snapshot Home Position)..... 140
- 24. Glossary 141**
- 25. Document Revision History 142**

2. Introduction

Communication interface:

All TANGO controllers communicate via a serial COM port interface, independent of the controller type (RS232C, USB, PCI, PCI-E). The default setting is 57600,8,2,N.

Axes:

TANGO controllers are available with up to 4 axes. The axis specifiers used in the TANGO instruction set are the ASCII characters *x*, *y*, *z*, and *a*. Axes can be addressed individually by using the axis specifier or combined if no axis is specified in the instruction.

Instruction syntax:

The instructions and parameters are sent as cleartext ASCII strings with a terminating carriage return [CR], which is 0x0d hex. Characters may be upper-, lower- or camel-case. The parameters are separated by a space character. This provides easy access to all functions by using a simple terminal program such as HyperTerminal. A typical instruction syntax is as follows:

```
[!,?][instruction][SP][optional axis] [parameter1][SP][parameter2] [etc...] [CR]
```

[!,?] Read/write specifier, required by most instructions:

! (exclamation mark) = to write parameter, execute an instruction etc.

? (question mark) = to read data (returns settings, or status, etc.)

[instruction] Is the instruction word itself.

[SP] Space (ASCII 0x20 hex) as separation.

[optional axis] Axis character *x*, *y*, *z* or *a* if only one axis must be addressed.

[parameter] Usually integer or floating point numbers, floating point uses decimal point, no comma.

[CR] Termination (ASCII 0x0d hex), causes instruction execution.

A read instruction may return more than one parameter. In many cases the number of returned parameters depends on the amount of available axes:

```
[axis X] [if available: axis Y] [if available: axis Z] [if available: axis A]
```

For some instructions that return fractional numbers (e.g. *?pitch*, *?gear*, *?vel*, *?encperiod* and more) the number of returned fractional digits can be specified in order to increase resolution when reading back the value. For *'?pos'* and similar position returning functions (e.g. *'lim'*), the number of fractional digits can be set by the **'resolution'** parameter.

Syntax examples:

```
!vel 10 1.5      set velocities for the first two axes
!cal            command all axes to perform a calibration move
!moa y 10.1     move y axis to absolute position 10.1
?pos           returns position of all axes (e.g. 0.0000 0.0000 0.0000)
?vel x         returns velocity setting of X axis only (e.g. 10.000)
```

Moves:

Move instructions are executed as a vector move. If several axes are started with one instruction they will reach their destinations at the same time. This means that - depending on velocity, acceleration and travel distance - one leading axis travels at its full velocity while the others follow synchronously. To move axes independently with their individual velocities, they have to be started separately by using single axis instructions. Please refer to the "move" instruction descriptions.

Settings:

Most settings can be stored permanently in the TANGO controller, so they are available from power on. When stored once, this reduces initialization overhead of the application software. Refer to the "save" instruction for further information. Parameters that are saved can be identified by a 'Y' in the Save column of the **brief instruction set description** later in this document.

Character limits:

To prevent the input buffer from overflow, please do not send more than 255 characters at once.

Such may occur when sending the setup sequence to the TANGO controller. A good practice is to request the "?err" state after each setup instruction. This will return the information if the parameters were accepted or not while preventing overflow.

Another solution is to activate the "!cts" handshake (available only with Desktop RS232C and some USB versions). This will automatically halt the PC transmission for as long as the input buffer is full. The PC COM port then must be opened with hardware handshake on, as well. Please refer to the "!cts" instruction description.

Important: Security speed limitation!

The TANGO controllers have a built in security function, which reduces the maximum travel velocity to a secure 10mm/s for as long as no initial "cal" and "rm" moves have been executed. This is to safeguard the driven axis against damage that could be caused by moving fast into its end positions. After calibrating the axis into its endswitches (cal and/or rm if switches are mounted and enabled) the travel velocity is no longer limited.

If it is not wanted or impossible to do a calibration and range measure move on each power on:

- A) The speed limit may be increased to up to 100mm/s at own risk. Please refer to the "secvel" instruction for further information.
- B) The !rm can be skipped by instead using !vrm (please read remarks).
- C) Non existent limit switches can be deactivated (swact) and then do not require a !rm. In such case secvel will be released after !cal.

Important: Measuring units!

The measuring unit is set by the "dim" instruction, where dim 2 [which is mm] is the default setting.

In all dim settings, except of dim 9, the velocity is in motor revolutions per second! Only dim 9 provides the millimeter unit for most parameters¹, positions and velocities.

Extended mode:

In addition to the improvements when using dim 9 units, there is an option to enable extended mode behavior. It enables more functionality, like separate calibration, rm and joystick velocities, which else are the same as the axis velocity (vel). Please refer to the "extmode" instruction for further details.

¹ Only 'calbspeed' and 'calrefspeed' are always in 1/100 turns/sec, even in dim mode 9

3. Hint for controller initialization

The Tango controller must be configured to meet the hardware requirements. The configuration can be stored permanently with the **save** instruction. It is recommended to save and reboot the controller after changing the setup parameters (e.g. **!usteps**, **!pitch**, **!gear**) to ensure all changes will be applied.

- The axis units: **!dim**
- The **!extmode** (0 or 1)
- The axis **!pitch** (always in [mm], independent of **dim**)

Dim 9 and Extmode:

Using *dim=9* and *extmode=1* instead of *dim=2* will turn all units (also *vel* and *joyvel*) to [mm] and [mm/s]. *Extmode=1* offers bugfixes, more features (e.g. separate *joyvel*) and flexibility. But it has a slightly different behavior. Please refer to the **Extended Mode** description in this document.



Brief Description of the TANGO Instruction Set

Controller Informations					
Instruction	Example	Save	Brief description	Page	
(?)	version	version	-	Read detailed firmware and controller version	17
(?)	det	det	-	Read the controller configuration	18
(?)	detext	detext	-	Read the controller configuration with description	18
?	readsn	?readsn	-	Read the controller serial number	19
(?)	ver	ver	-	Read default version number	19
(?)	iver	iver	-	Read further version number information	19
(?)	uptime	uptime	-	Read how long the controller is running	20
(?)	temp	temp	-	Read case temperature (avail. depends on controller type)	20
?	maxaxis	?maxaxis	-	Read number of available axes	20
?	maxcur	?maxcur	-	Show the maximum possible motor currents of all axes	20
?	etspresent	?etspresent	-	Check availability of ETS	21
?	stagesn	?stagesn	-	Read the axis serial numbers from ETS	22

Communication Interface Settings					
Instruction	Example	Save	Brief description	Page	
? !	baud	lbaud 9600	Y	Set RS232 baud rate to 9600 Bd (default=57600)	23
? !	cts	lcts 1	Y	Enable CTS hardware handshake	23

System Instructions					
Instruction	Example	Save	Brief description	Page	
(!)	save	save	-	Save parameters to controller nonvolatile memory	24
(!)	restore	restore	-	Reload saved controller parameters from n.v. memory	24
(!)	reset	reset	-	Reset controller (forces restart, similar to cycle power)	25
!	pa	!pa 1	-	Enable power amplifiers (disable = 0), see also 'axis' instr.	25
? !	ipreter	lipreter 2	Y	Select optional Venus instruction set	26

Operating Modes					
Instruction	Example	Save	Brief description	Page	
? !	extmode	!extmode 1	Y	Enable extended controller behavior	27
? !	scanmode	!scanmode 1	Y	Set positioning behavior to scanmode	28
? !	scanvel	!scanvel 0.5	Y	Set scanmode vector velocity to 0.5 mm/s	28
? !	modulomode	!modulomode a 1	Y	Set positioning behavior of A axis to turntable mode 1	29

Controller States and Error Messages					
Instruction	Example	Save	Brief description	Page	
? !	autostatus	!autostatus 0	-	Select autostatus response type 0 (=disabled), range: [0-4]	30
(?)	statusaxis	statusaxis	-	Read axis state [@,M,J,C,S,A,D,-]	31
(?)	corrst	corrst x	-	Read state of position correction	31
(?)	status	status	-	Read controller error state	32
(?)	err	err	-	Read error number	32
(?)	help	help	-	Read error number with additional description text	32
(?)	service	service	-	Returns a detailed parameter and state list, for debugging	33
(?)	pci	pci	-	Returns 1 if controller is plugged in a PCI slot (desktop=0)	33
(?)	isvel	?isvel x	-	Read actual velocity of the X axis	33
?	maxpos	?maxpos x	-	Read maximum available position range for X axis	34

General Adjustments				
Instruction	Example	Save	Brief description	Page

**General Adjustments**

Instruction	Example	Save	Brief description	Page
? ! dim	!dim 1 1 1	Y	Set position units of X Y Z to μm	35
? ! pitch	!pitch 1 1 1	Y	Set spindle pitch of X Y Z to 1 [mm/revolution]	36
? ! gear	!gear 1 1 1	Y	Set gear factor of X Y Z to 1	36
? ! motorsteps	!motorsteps x 200	Y	Set X axis motor has 200 steps per revolution	37
? ! accel	!accel 0.1 0.1 0.1	Y	Set acceleration of X Y Z to 0.1m/s^2	38
? ! accelfunc	!accelfunc 1 1 0	Y	Set acceleration function X and Y to \sin^2 , Z to linear	38
? ! stopaccel	!stopaccel 2 2	Y	Set X and Y deceleration during stop condition to 2m/s^2	39
? ! vel	!vel 10 10 10	Y	Adjust speed of X Y Z to 10 [revolutions/s]	40
? ! velfac	!velfac 1 1 1	Y	Set velocity reduction factor for X Y Z to 1 (= no reduction), range is [0.01-1]	41
? ! secvel	!secvel x 20	Y	Set secure speed limit X to 20mm/s (unit is always mm/s)	41
? ! cur	!cur 0.5 0.6 1	Y	Set motor current in Ampere: X=0.5 Y=0.6 and Z=1 A	42
? ! reduction	!reduction 0.5 0.5 0.5	Y	Select 50% motor current reduction for X Y Z	43
? ! curdelay	!curdelay 1000	Y	Delay X axis motor current reduction by 1000 [ms]	43
? ! ecomove	!ecomove 30 30 0	Y	Set eco-level of X and Y to 30% current saving	44
? ! axis	!axis 1 0 -1	Y	Enable X, disable Y and switch off Z axis	45
? ! axisdir	!axisdir 0 1 0	Y	Reverse rotating direction of Y motor (caution!)	45
? ! motortable	!motortable x 2	Y	Select custom motor correction table type 2 for X axis	46
? ! usteps	!usteps 50000	Y	Set dim 0 microsteps to 50000/rev for all axes	46
? ! resolution	!resolution 6	Y	Set position return string resolution to 1 nm	47
? ! backlash	!backlash 12.3 0 0	Y	Set backlash compensation to $12.3\mu\text{m}$ in X and 0 in Y & Z	47
! ? lock	!lock 2 1	Y	Set write protection for parameter 2 (here: motor current)	48
! ? lockaxis	!lockaxis 0 0 0 0	Y	Remove lock protection from all axes (lock has no effect)	48
? lockstate	?lockstate x	-	Read extended locked parameters, including internal limitations currently applied to X axis	49
? ! stout	!stout 2	Y	Make Status-LED state available at AUX-I/O Pin VR_OUT	49
? ! noled	!noled 1	Y	Switch Status-LED permanently off	50
? ! updelay	!updelay -5000	Y	Wait to a maximum of 5 seconds for valid external power	50

Limit Switch Instructions (Hardware and Software)

Instruction	Example	Save	Brief description	Page
? ! lim	!lim 0 10 0 10 0 10	-	Set lower position limit to 0 and upper limit to 10 (assume unit is [mm] if dim was set to 2) for X Y Z	51
? ! limctr	!limctr x 1	-	Enable hardware limit switches for X axis, default = 1	51
? ! nosetlimit	!nosetlimit 1 1 1 1	Y	Disable setting/overwriting of software limits during cal and rm for all axes (here: X Y Z A), default = 0	52
? ! swtyp	!swtyp 1 0 1 !swtyp y 0 0 0	Y	Set limit switch type for all axes to NPN (pull-up) Set limit switch type for Y to PNP (pull-down)	52
? ! swpol	!swpol 1 0 1 !swpol z 1 0 1	Y	Set polarity of limit switches for all axes to active high (=1) Set polarity of limit switches for Z to active high	53
? ! swact	!swact 1 0 1 !swact y 1 0 0	Y	Enable cal and rm limit switches for all axes Enable cal limit switch for Y, disable ref and rm	54
? ! swdir	!swdir x 1	Y	Swap CAL and RM endswitch assignment of X axis	53
? readsw	?readsw	-	Read states of all limit switches (1=active and actuated)	55
(?) swin	swin	-	Read TTL signal level of all limit switch inputs (1=high)	55
(?) statuslimit	statuslimit	-	Read current limit status „A“ = calibration done „D“ = rm done „L“ = limit switch modified by software „-“ = not yet modified	56

Calibration and Range Measure Instructions



Instruction	Example	Save	Brief description	Page
(!) cal	cal	-	Perform a calibration move for all enabled axes, see 'axis'	57
(!) rm	rm x	-	Perform a range measure move in X	58
(!) vrm	vrm 75 50	-	Virtual range measure for a 75x50 microscope stage	59
? ! calmode	!calmode 2 2	Y	Set calibration/closed loop behavior X, Y to type 2	60
? ! calrequired	!calrequired z 1	Y	Z axis does not move until !cal is executed	60
? ! caltimeout	!caltimeout 60 60 10	Y	Set calibration timeout for X and Y to 1 minute, Z to 10s	61
? ! caliboffset	!caliboffset 1 1 1	Y	Set the cal zero-point 1mm aside lower limit switch (dim 2)	62
? ! rmooffset	!rmooffset 1 1 1	Y	Set rm end-position 1mm aside upper limit switch (dim 2)	62
? ! caldir	!caldir z 1	Y	Dummy function, please use axisdir instruction	62
? ! calbspeed	!calbspeed 20	Y	Set the speed for move out of 'cal' and 'rm' limit switches for all axes to 0.2 [revolutions/s], range is [1...100]	63
? ! calrefspeed	!calrefspeed 10	Y	Set the speed for calibrating to the encoder reference for all axes to 0.1 [revolutions/s], range is [1...100]	63
? ! encrefvel	!encrefvel 5 5 5	Y	Set the speed for calibrating to the encoder reference for axes X,Y,Z to 5 [rev/s] if dim=2, [mm/s] if dim=9	64
? ! calpos	calpos	-	Read back the encoder position where the calibration switch was released	65
? ! refdir	?refdir y	Y	Read the direction for encoder reference search in Y axis	64
? ! calvel	!calvel x 10 0.5	Y	Only if extmode = 1: Set calibration velocities in X	66
? ! rmvel	!rmvel x 10 0.5	Y	Only if extmode = 1: Set range measure velocities in X	67
? ! autopitch	!autopitch x 1	Y	Measure pitch after cal move of X axis	67

Move Instructions

Instruction	Example	Save	Brief description	Page
(!) moa	moa 10 10 10 moa y 20	-	Move X Y Z absolute to positions 10 10 10 Move Y axis to position 20 (unit depends on dim setting)	69
(!) mor	mor 4 4 4 mor y -10.5	-	Move X Y Z relative by 4 (unit depends on dim setting) Move Y axis relative 10.5 backwards	69
(!) m	m	-	Move relative again (use same parameters as defined by last '!mor' or '!distance' instruction)	70
? ! distance	!distance 1 1 1	-	Set distance for X Y Z 'm'-move (start with 'm' or '!m')	70
(!) moc	moc x	-	Move X to center position between lower and upper limit switch, or between lower and upper software limits	70
(!) go	go x 12.5	-	Move X to pos. 12.5, overwriteable, for tracking applications	71
? ! speed	!speed 5 5 5 !speed y 0	-	Let X Y Z axis travel at 5 [revolutions/s] Stop the Y axis speed move	72
(!) a	a	-	Abort move (Stop)	72
? ! delay	!delay 1000	Y	Delay the start of move instructions by 1000 ms	73
? ! pause	!pause 10	Y	Delay "position reached" autostatus response by 10 ms	73
? ! pos	!pos 0 0 1.5 ?pos z	-	Set current X Y positions to 0 and Z position to 1.5 Read current Z position	74
(!) posclr	!posclr x	-	Reset the position offset that was manipulated by !pos	74
(!) zero	!zero z	-	Set Z position and internal counter to 0 (e.g. filter wheel application)	75
(!) clearpos	!clearpos z	-	Set Z position and internal counter to 0 (e.g. filter wheel application), not executable with measuring system	75

HDI Instructions (Joystick, Trackball, ERGODRIVE)

Instruction	Example	Save	Brief description	Page
? ! joy	!joy 0 !joy 2	Y	Switch joystick ON=2 or OFF=0 (Switching off may cause an autostatus response)	76
? ! joydir	!joydir 2 -2 0	Y	Set HDI axis direction: Y reversed, Z disabled	77
? ! joychangeaxis	!joychangeaxis 1	Y	Change Joystick X and Y axis (X→Y, Y→X)	77
? ! joywindow	!joywindow 14	Y	Set idle window of the joystick center position, where a joystick deflection has no effect [0..100]	77

**HDI Instructions (Joystick, Trackball, ERGODRIVE)**

Instruction	Example	Save	Brief description	Page
? ! joyvel	!joyvel z 1.5	Y	Only if extmode = 1: Set joystick velocity for Z to 1.5	78
?(!) joyspeed	joyspeed 2 25	Y	Set joystick speed for speed button 2 “medium” to 25 rev/s	78
? ! keymode	!keymode 2	Y	Select joystick key mode 2 = high speed preselection	79
? ! keyspeed	!keyspeed x 5 20	Y	Set keymode joystick speed X low=5mm/s, high=20mm/s	80
?(!) joycurve	!joycurve z 1	Y	Set joystick characteristic for Z ot linear	80
(?) key	key	-	Read state of all joystick buttons (0=released, 1=pressed)	81
(?) keyl	keyl	-	Read and clear latched state of all joystick buttons	81
? ! hwfactor	!hwfactor x 1	Y	One coaxial drive knob revolution in X is 1mm axis travel	82
? ! hwfactorb	!hwfactorb x 14	Y	One coaxial drive knob revolution in X is 14mm axis travel	82
? ! hwfilter	!hwfilter 0	Y	Deactivate coaxial drive noise reduction	82
? ! tbfactor	!tbfactor 1 1	Y	Set trackball transmission factor in X and Y to default	83
(?) zwheel	?zwheel	-	Returns 1 if HDI device has a multi-function wheel	84
?(!) zwtravel	!zwtravel 1 0.25	Y	Set default multi-function wheel travel to 2.5 mm/rev	84
? ! zwaxis	!zwaxis a	Y	Assign multi-function wheel to A-axis	85
? ! zwfactor	!zwfactor 1	Y	Set multi-function wheel factor to 1:1 (default)	85
? ! tvrjoy	!tvrjoy z	Y	Assign AUX-IO pulse&direction device to Z axis	86
? ! tvrjoyf	!tvrjoyf 1	Y	Set tvrjoy transmission factor to 1	86
(?) hdi	hdi	-	Read ID number of the connected HDI device	87
! ? hdimode	!hdimode 0 1	Y	Set hdimode bit 0 to 1 for ERGODRIVE Toggle Mode	88
! ? configaxsel	!configaxsel 1	Y	Toggle joystick Z-axis between axes Z and A by F4 key	89

Digital and Analogue I/O

Instruction	Example	Save	Brief description	Page
(?) digin	digin digin 8	-	I/O1 Extension module: Read all digital inputs I/O1 Extension module: Read digital input 8	91
? ! digout	!digout 5 1 ?digout	-	I/O1 Extension module: Set digital output 5 to logic level 1 I/O1 Extension module: Read back all digital output levels	91
? ! diginpol	!diginpol 5 1	Y	I/O1 Extension module: Invert input 5 signal	92
? ! digintyp	!digintyp 111111	Y	I/O1 Extension module: Apply pull-up resistor to all inputs	92
? ! digoutpreset	!digoutpreset 3 1	Y	I/O1 Extension module: Preset state of output 3 to high	93
(?) edigin	edigin edigin 8	-	Multi I/O Extension: Read all digital inputs Multi I/O Extension: Read digital input 8	94
? ! edigout	!edigout 5 1 ?edigout	-	Multi I/O Extension: Set digital output 5 to logic level 1 Multi I/O Extension: Read back all digital output levels	94
? ! ediginpol	!ediginpol 5 1	Y	Multi I/O Extension: Invert input 5 signal	95
? ! edigintyp	!edigintyp 111111	Y	Multi I/O Extension: Apply pull-up resistor to input 0-5	95
? ! edigoutpreset	!edigoutpreset 3 1	Y	Multi I/O Extension: Preset state of output 3 to high	96
(?) adigin	adigin adigin 2	-	Read all AUX-I/O digital inputs Read logic level of AUX-I/O digital input 2 only	97
? ! adigout	!adigout 3 1 ?adigout	-	Set AUX-I/O digital output 3 to logic level 1 Read back all digital output levels	97
(?) anain	anain c 2	-	Read input of analogue channel 2	98
? ! anaout	!anaout c 1 17.5	-	Set analogue voltage of channel 1 to 17.5 percent (1.75V)	99
? ! anamode	!anamode 0	N	Set analogue output mode to default behavior	99
? ! stoppol	!stoppol 1	Y	Set AUX-IO stop input to active high	100
! stop	!stop 0	-	Release stop condition (in latched stoppol modes 4 or 5)	101
? ! shutter	!shutter 1	-	Set AUX-IO shutter out signal to TTL high	101
(!) flash	flash 0.1	-	Send a 100µs high pulse to AUX-IO TAKT_OUT (LED)	102

Encoder Instructions

Instruction	Example	Save	Brief description	Page
? ! encmask	!encmask 1 1 0	Y	Enable activation of X and Y encoders, disable Z	103

**Encoder Instructions**

Instruction	Example	Save	Brief description	Page
? ! enc	!enc 1 0	-	Manually activate X encoder (caution!), set Y to inactive	104
? ! encperiod	!encperiod 0.1	Y	Set signal period of X encoder to 100 μ m	104
? ! encctl	!encctl x 1	Y	X encoder is TTL type (has no analogue sin/cos signal)	106
? ! encdir	!encdir y 1	(Y)	Reverse counting direction for Y encoder	105
? ! encvel	!encvel x 0.5	Y	Set auto-adjust velocity of X encoder to 0.5mm/s	105
? ! encref	!encref 0	Y	Disable usage of X encoder reference signal	106
? ! encnas	!encnas 1 0 0	Y	Enable NAS error signal input encoding for X encoder only	107
(?) encrefstatus	encrefstatus x	-	Read X encoder reference signal state (1=on reference)	107
(?) encrefstatusl	encrefstatusl x	-	Read latched X encoder reference signal state	107
(?) encnasstatus	encnasstatus x	-	Read X encoder NAS signal state (1=NAS error)	108
? ! encerr	!encerr 0	-	Clear encoder error state for X axis (? response is 0 or e)	108
? ! encamp	?encamp x	-	Read X encoder signal amplitude in percent	108
? ! encpos	!encpos 1	-	?pos instruction returns for the encoder positions, if enc=1	109
(?) hwcount	hwcount	-	Read all encoder positions (TTL counter, no interpolation)	109
(!) clearhwcount	clearhwcount x	-	Set X axis hwcount to zero	109

MR Encoder Instructions

Instruction	Example	Save	Brief description	Page
? ! mra	?mra x	-	Read amplitude correction factor (sin/cos ratio) of X	110
? ! mro	?mro	-	Read offset correction value for all encoders	110
? ! mrp	!mrp x 0 0 0 0	-	Reset MR-signal peak-to-peak measurement result of X	111
? mrt	?mrt z 2	-	List two measurement results of the Z input signals	111

Closed Loop Instructions

Instruction	Example	Save	Brief description	Page
? ! ctr	!ctr 1 1 1	Y	Set closed loop circuit X Y Z to "active until reached" mode	112
? ! ctrf	!ctrf 2.0	Y	Closed loop factor for X axis is set to 2.0	113
? ! ctrff	!ctrff 2 3.5	Y	Closed loop factors for X axis are set to 2 and 3.5	113
? ! ctrc	!ctrc 3	Y	Closed loop control is called every 3 millisecond	114
? ! ctrd	!ctrd 100	Y	Closed loop in target window for 100 milliseconds	114
? ! ctrt	!ctrt 200	Y	Closed loop control timeout after 200 milliseconds	114
? ! twi	!twi 0.01 0.01 0.01	Y	Set target window for X Y Z to 10 μ m (assume dim=2)	115
? ! ctrsm	!ctrsm x 1	Y	Set X behavior outside lock-in range to "slow closed loop"	115
? ! ctrs	!ctrs x 0.2	Y	Set lock-in range for X to 0.2mm (assume dim=2)	116
? ctrstatus	?ctrstatus 1	-	Get Closed Loop active state of all axes	117
? ctrdiff	?ctrdiff	-	Get Closed Loop position difference of all axes	118

Trigger Output Functionality¹

Instruction	Example	Save	Brief description	Page
? ! trig	!trig 1	-	Enable trigger functionality (should be the last instruction)	119
? ! triga	!triga x	Y	Trigger function is related to X axis	119
? ! trigm	!trigm 0	Y	Select trigger mode 0	120
! ? trigo	!trigo 1	Y	Select the default trigger signal output	121
? ! trigs	!trigs 40	Y	Set trigger output signal length to 40 microseconds	122
? ! trigd	!trigd 10	Y	Set trigger distance to 10 (mm if dim=2)	121
? ! trigcomp	!trigcomp 50	Y	Compensate a trigger signal delay of 50 μ s	122
? ! trigenc	!trigenc 1	Y	Select encoder signal as trigger source (if available)	123
? ! trigf	!trigf 1000	Y	Set periodic trigger pulse frequency to 1kHz	123
? ! trigbwidth	!trigbwidth 4.35	Y	Set Precise secondary trigger out signal length to 4.35 μ s	124

¹ Function has to be enabled by factory, it is not available per default.

**Trigger Output Functionality¹**

Instruction	Example	Save	Brief description	Page
? ! trigbdelay	!trigbdelay 15.05	Y	Set Precise secondary trigger out to 15.05µs delayed	124
? ! trigbf	!trigbf 66000000	Y	Set Precise secondary trigger out frequency to 66 MHz	124
? ! trigcount	?trigcount	-	Read number of generated trigger events	125
(!) trigger	trigger	-	Manually set trigger output (available in trigm 102, 103)	125
? ! trigr	!trigr 5 10 6	-	Generate 6 trigger signals from 5 to 10→5,6,7,8,9,10 (mm)	126

Snapshot - Trigger Input Functionality¹

Instruction	Example	Save	Brief description	Page
? ! sns	!sns 1	-	Enable snapshot functionality (always 1 after power up)	133
? ! sns1	!sns1 0	Y	Set snapshot input signal to active low	133
? ! snsf	!snsf 10	Y	Set snapshot signal debounce filter to 10 milliseconds	133
? ! snsrm	!snsrm 0	Y	Set snapshot mode to 0 (0=capture pos, 1=move to pos)	134
? ! snsr	?snsc	-	Read number of snapshot events (=array fill size)	136
? ! snsi	!snsi 5	-	Set snapshot index to 6 th entry (snsa 6)	136
? ! snsaxis	!snsaxis 1 1 0 0	-	X and Y axis moves wait for snapshot (in snsrm mode 6)	137
? ! snsp	?snsp x	-	Read last captured X position	138
? ! snsax	?snsax 1	-	Read first position entry of snapshot array (all axes)	138
(!) snse	snse 2	-	Generate SnapShot event F2	139
? ! snsv	?snsv 3	-	Read captured ANIN0 voltage in mV of 3 rd snapshot entry	139
? ! prehome	!prehome 10 20 1	-	Set prehome positions X Y Z to 10 20 1 (unit depends on dim setting)	140
? ! home	!home 5 5 0	-	Set home positions X Y Z to 5 5 0 (unit depends on dim setting)	140

4. Instruction Syntax Description

Most instructions work in both directions (reading and writing). (?)! means the instruction accepts write and read access. The controller identifies a read instruction by a preceding '?', while '!' indicates writing to a parameter or executing an instruction. More information can be found in the **Introduction** chapter of this document.

Some examples of legal instruction syntax:

```
!Instruction parameter1 parameter2 parameter3 parameter4
!Instruction parameter1 parameter2
!Instruction axis parameter
!Instruction
?Instruction axis parameter
?Instruction
```

5. Error Numbers and their possible Root Cause

```
0    no error
1    no valid axis name
2    no executable instruction
3    too many characters in command line
4    invalid instruction
5    number is not inside allowed range
6    wrong number of parameters
7    either ! or ? is missing
8    no TVR possible, while axis active
9    no ON or OFF of axis possible, while TVR active
10   function not configured
11   no move instruction possible, while joystick enabled
12   limit switch active
13   function not executable, because encoder detected
21   multiple axis moves are forbidden (e.g. during initialization)
22   automatic or manual move is not allowed (e.g. door open or initialization)
27   emergency STOP is active
29   servo amplifier are disabled (switched OFF)
30   safety circuit out of order

70   wrong CPLD data
71   ETS error
72   parameter is write protected (check lock bits)
73   internal error, e.g. eeprom data corruption
74   closed loop switched off due to parameter change
75   could not enable axis correction, or axis correction was disabled
76   io extension card error (output overload)
77   io extension card communication error (internal bus error)
```



6. Controller Informations

The firmware version may be read by sending the instruction '**version**' to the controller. The instruction '**det**' gives further details of which options and features are enabled. Each controller has its own unique serial number readable with the instruction '**readsn**'.

6.1. version (Read detailed Version information)

Syntax: ?version or version
Parameter: none or 1

Description: Read the TANGO type and firmware version.

Sending the version instruction with parameter 1 returns the TANGO firmware version number only.

Response syntax: Character string including controller type, firmware version and build date separated by a comma, e.g.
TANGO-DT-S, Version 1.57, Apr 17 2012 , 12:12:02

TANGO-DT	Desktop version, PCI card based
TANGO-DT-S	Desktop version, PCI-S card based
TANGO-DTe	Desktop version, PCI-E card based
TANGO-PCI	PCI card
TANGO-PCI-S	PCI-S card
TANGO-PCIE	PCI-E card (PCI Express)
TANGO-MINI	TANGomini
TANGO-C	Motorized stage with integrated controller
TANGO-I	Tango integrale controller
Version 1.57	Firmware version number
Apr 17 2012	Firmware build date
12:12:02	Firmware build time

Example:

```
?version ==> TANGO-DT-S, Version 1.57, Apr 17 2012 , 12:12:02  
?version 1 ==> 1.57
```

6.2. det (Read detailed Configuration)

Syntax: ?det or det
Parameter: none

Description: Read detailed information of the controller configuration.

Response: The response is a decimal integer number. Its bit pattern represents the configuration as described below:

```
0x0 - - - 1     configured encoder interface = 1Vpp
0x0 - - - 2     configured encoder interface = MR
0x0 - - - 4     configured encoder interface = TTL
0x0 - - - 8     configured encoder interface = Universal (1V+MR)
0x0 - - 3 -     the number of configured axes (e.g. 3)
0x0 - 1 - -     Display is configured
0x0 - 2 - -     Speedpoti is configured
0x0 - 4 - -     Hand wheel is configured
0x0 - 8 - -     Snapshot is configured
0x0 1 - - -     TVRin is configured
0x0 2 - - -     Trigger out is configured
0x0 8 - - -     TVRout is configured
0x1 - - - -     digital extension: I/O1           (24in+8out)
0x2 - - - -     digital extension: Multi I/O (12in+8out)
0x4 - - - -     Trackball is configured
0x8 - - - -     ETS is connected
```

Individual configured options can be identified by applying a logic AND mask to the returned value.

E.g. (val & 0x0800) to identify if Snapshot instructions are available/configured by factory, (val & 0x02000) for Trigger.

Example: Assume the ?det response is 81697, which is 0x13F21 hex. This number means in detail, that the controller is configured for:

```
1 => Built in digital I/O extension with 24in + 8out
3 => TVRin and Trigger out
F => Display, Speedpoti, Hand wheel and Snapshot
2 => 2 axes
1 => 1Vpp encoder
```

6.3. detext (Read Extended detailed Configuration)

Syntax: ?detext or detext
Parameter: none

Description: Read Detailed information of the controller configuration as multi-line readable text (description strings). Each line is terminated by a [CR].

Response: Multi line reply, containing the configuration number as hex value (bit representation as describet with 'det'), and the meaning of it as multi line text.

Example:
detext => 02832
 = MR Encoder
 = 3 Axes
 = Snapshot
 = Trigger out

6.4. readsn (Read Serial Number)

Syntax: ?readsn or readsn
Parameter: none

Description: Reads the serial number of the TANGO controller.

Response: The controller returns its unique serial number as ASCII character string. The syntax is YYWWTNXXX.

YY year of manufacturing
WW week of manufacturing
T type identifier
N in hardware available axes (may differ from ?maxaxis)
XXX index number

Example: ?readsn => 083303007

6.5. ver (Read default Version Number)

Syntax: ?ver or ver
Parameter: none

Description: Read the default controller version info. The first digit is the number of configured axes. The second digit is the maximum possible motor current in ampere.
To read the TANGO firmware version, please use "version".

Response syntax: Vers:LSnm.xx.xxx (in some cases "Vers:ESnm.xx.xxx")

"Vers:LS" Fixed character string (also "Vers:ES" possible)
n Number of configured axes: 1, 2, 3, or 4
m Maximum Motor current: 1=1.25A, 2=2.5A, 3=3.75A
x Fixed numbers

Example: ?ver => Vers:LS32.00.038 (=3 axis 2.5 A)

6.6. iver (Read internal Version Number)

Syntax: ?iver or iver
Parameter: none

Description: Read the internal version information string. Mostly unused.
To read the TANGO firmware version, please use "version".

Response syntax: 14 characters, e.g. T[DD].[WW].[YY]-[NNNN]
[DD] = Day of Week
[WW] = Week
[YY] = Year
[NNNN] = Number

Example: ?iver => T04.35.02-0004

6.7. uptime (Read Controller Up Time)

Syntax: ?uptime or uptime
Parameter: none

Description: This instruction returns the power-on time of the controller since it was switched on or resetted.

Response: Time in seconds.

Example: uptime => 8731

6.8. temp (Read Case Temperature)

Syntax: ?temp or temp
Parameter: none

Description: Read the ambient temperature inside the controller.
Remarks: Not all TANGO controllers provide a temperature sensor.

Response: Temperature in [°C] with one decimal place.

Example: temp => 28.9

6.9. maxaxis (Read number of available Axes)

Syntax: ?maxaxis
Parameter: none

Description: Read the number of available (factory configured) axes.
1, 2, 3 or 4.

Response: Number of available axes.

Example: ?maxaxis => 3

6.10. maxcur (Read Maximum Motor Current)

Syntax: ?maxcur
Parameter: x, y, z, a or none
Optional parameter 1

Description: Read the maximum possible motor current which can be set by **!cur**.

A) Maxcur called without parameter:
Maximum motor current which the power amplifier can deliver.

B) Maxcur called with parameter "1":
Motor current limitation, set by the connected axis (via ETS).

Response: maximum motor current in Ampere [A] (e.g. "1.25" or "1.00")

Examples:

?maxcur y read maximum adjustable motorcurrent of Y axis only
?maxcur read maximum adjustable motorcurrent of all available axes
(e.g. returns 1.25 1.25 1.25 1.00)

?maxcur y 1 read motor current limitation of Y axis only (e.g. set by ETS)
?maxcur 1 read motor current limitation of all axes (e.g. set by ETS)

6.11. etspresent (Read ETS Detect State)

Syntax: ?etspresent
Parameter: none

Description: Check if an ETS was detected by the TANGO (during power-up).

0 = No ETS found at the corresponding address
1 = ETS was found at the corresponding address (is available)

Remarks: If more than one ETS is found, the first one (lowest address) is treated as the "main" ETS, the ETS with higher address only for the there defined axis specific parameters (e.g. axis 3).

Response: ASCII string of 4 characters, 0 or 1
 [ETS ADR0][ETS ADR1][ETS ADR2][ETS ADR3]

Example: ?etspresent => 0000 (no ETS connected)
 ?etspresent => 1000 (ETS found at address 0, usual case)
 ?etspresent => 1010 (ETS found at address 0 and 2)



6.12. stagesn (Read Connected Devices Serial Number)

Syntax: ?stagesn
Parameter: none or -1,0,1,2,3

Description: Read the device serial number from the ETS.
If the motor axis provides the ETS identification circuit, the serial number of the axis or connected unit (e.g. a microscope stage) is returned.

Call parameter options:

- None: 4 serial numbers are returned, one for each possible ETS address (0,1,2,3)
- -1 : 1 Serial number is returned, of the main ETS (usually also the only connected ETS, recommendet instruction)
- 0-3 : Addresses an individual ETS, usually only ETS#0 is Available (which then also responds with -1 param.)

Response: ASCII string(s) of 8 or 9 characters.
The syntax is YYMMDDXXX or "-----" if no ETS available.

YY year of manufacturing
MM month of manufacturing
DD day of manufacturing
XX(X) index number

```

Example: ?stagesn      => 120328015 -----
         ?stagesn -1 => 120328015
         ?stagesn 0  => 120328015
         ?stagesn 1  => -----

         ?stagesn -1 => 07090305

         ?stagesn      => ----- 120328015 -----
         ?stagesn -1  => 120328015
         ?stagesn 0   => -----
         ?stagesn 1   => 120328015

```

7. Communication Interface Settings

7.1. baud (Baud Rate)

Syntax: !baud or ?baud
Parameter: 1200, 2400, 480, 9600, 19200, 38400, 57600 or 115200

Description: Set or read the baudrate of the serial COM Port interface.

It applies to devices with a true RS232 serial connection, as available with TANGO-DT, TANGomini (RS232 and USB versions) and the USB Pilot stage.

Remarks: For PCI/PCI-E card versions or TANGO-DT with USB interface this instruction has no effect, as communication is managed by the driver at a very high, internally fixed baudrate. In this case it does not matter which baudrate the virtual COM port is opened with, it has no effect on performance.

After sending this instruction the PC has to re-open the COM Port with the new baudrate, else no communication is possible. Then a **"!save"** instruction may be sent to permanently store the new baudrate in the controller.

Response: Current baud rate of the controller

Examples:
!baud 57600 Set the baud rate to 57600 [Bd]
?baud Read currently set baud rate

7.2. cts (Enable/Disable RS232 Hardware Handshake)

Syntax: ?cts or !cts
Parameter: 0 or 1

Description: Enable or disable RTS/CTS hardware handshake of the RS232 and USB Virtual COM Port interfaces. For PCI bus communication this instruction has no effect.

Remarks: The COM port of the PC has to be opened in the same hardware handshake mode.

0 : no handshake (default)
1 : RTS/CTS handshake

Response: Currently selected cts mode

Examples:
?cts read current handshake mode
!cts 0 disable RTS/CTS handshake (default, recommended)
!cts 1 enable RTS/CTS handshake

8. System Instructions

8.1. save (Save Parameters)

Syntax: !save or save
Parameter: none

Description: The save instruction permanently stores the parameter settings (e.g. spindle pitch, motor current) to the TANGO controller. These parameters will be applied as default values after each consecutive power-on or reset. Executing a save comand always returns the "OK..." string when writing to the internal memory has completed successfully.

Response: ASCII string "OK..." or "ERR"

Example: save
 ==> OK... (The currently used controller parameters are saved
 and from now on used as defaults)

8.2. restore (Restore Saved Parameters)

Syntax: !restore, restore or ?restore
Parameter: none or -1

Description: Reload or reset the saved parameters.

When called without parameter (restore, !restore, ?restore)

The controller reloads the parameter settings from its nonvolatile memory, like performed at power-on or reset. But restore does not affect or restart the entire hardware.

?restore returns "OK..." or "ERR" (like the save instruction), In the other cases there is no reply. ?err might be sent once after the restore instruction and will reply after restore has completed.

When called with parameter "-1" (restore -1, !restore -1)

The saved parameters (nonvolatile memory) will be deleted and set to the firmware defaults. The parameters then have to be checked and set to the hardware requirements by the user. Else it may cause damage (due to overcurrent, wrong pitch, limit switch types etc). Software reset is performed automatically.

There is no reply to the restore -1 instruction, ?err polling may be required as described with the software "reset".

Response: none, or "OK..." or "ERR" when using ?restore

Example: restore (reload the saved parameter set)
 ?restore (like restore, but with OK/ERR reply)
 restore -1 (reset the saved parameters to default)

8.3. reset (Force a Software Reset)

Syntax: !reset or reset
Parameter: none

Description: The controller is forced to perform a software reset. It is a restart similar to power on. Rebooting from reset will take more than 1 second, where the controller is not responding. There is no reply to a software reset.

Remarks: Wait for reboot after Reset:
For knowing if the controller has rebooted and is ready, data may be polled until it responds again. E.g. send "**?err**" until the controller responds:
Send ?err [wait 0.5s for response]
Send ?err [wait 0.5s for response]
...
Send ?err [wait 0.5s for response]
Send ?err => 0 [Response, controller is ready]

Response: none

Example: reset

8.4. pa (Enable or Disable the Power Amplifiers)

Syntax: !pa or !poweramplifier
 ?pa or ?poweramplifier
Parameter: 0 or 1

Description: Switch all motor amplifiers on/off or read amplifier state.

If switched off, no motor current is flowing (high impedance). To switch off individual axes, use the '**axis -1**' instructions.

Amplifier switch off can also be caused by a short circuit, the PSE pin functionality or loss of motor supply voltage. Then an internal error (error 29) is generated and the status LED flashes. ?pa will return 0. After removing the switch-off cause, the amplifiers can be switched on again by !pa 1.

1 = Amplifiers on
0 = Amplifiers off

Remarks: With amplifiers off it can not be ensured that the axis position will be retained. A closed loop will be deactivated.

Response: amplifier on state, 0 or 1

Example: !pa 1 Switch on all amplifiers
 ?pa Read amplifier on state

Sequence example: !pa 0
 ?pa => 0
 ?err => 0

External event: PSE, short circuit or no motor voltage applied
?pa => 0
?err => 29

8.5. ipreter (Select Instruction Set)

Syntax: !ipreter or ?ipreter
Parameter: 1, 2, 3 or 4

Description: Instruction set of the TANGO controller.
The TANGO controller provides 4 different instruction sets, also called "interpreter".
It is recommended to use the default interpreter 1, as it is the native language and supports the most complex instruction set available.
Other instruction sets may be used for compatibility to existing applications. They are described in separate manuals.

INTERPRETER NR.

```
-----  
0   Not supported! (old register instruction set)  
  
1   TANGO instruction set (default),  
    as described in this manual  
  
2   VENUS-1 and VENUS-2  
  
3   LUDL MAC5000  
  
4   ASI MS-2000 (Available with Firmware >= 1.46)  
-----
```

To return from the VENUS instruction set (2), please enter the string "1 setipreter" and press enter (or send an ASCII [CR]). For other instruction sets please refer to the corresponding instruction set description.

Response: 1, 2, 3 or 4

Example:
!ipreter 2 => Switch the interpreter to the VENUS instruction set
?ipreter => Responds the currently selected interpreter

9. Operating Modes

9.1. Extended Mode

Activating Extended Mode will change the controller's behavior. Also there are new instructions available for setting calibrate and range measure velocities.

Note: When initializing the controller, the desired Extended Mode should be set directly after setting **dim** and before setting gear, pitch, vel etc.

Calibration in extmode = 0:

!vel --> The velocity for moving towards a limit switch has to be set everytime before starting a **cal** / **rm** move.
!calbspeed --> There is only one velocity for all axes to travel out of the Limit switch. The unit is 1/100 rev/s.

Calibration in extmode = 1:

!vel has no influence to the **!cal** and **!rm** move, **calbspeed** is no longer used. Now the calibrate (**cal**) and range measure (**rm**) velocities can be assigned once and will be used as speed especially for this instructions.

!calvel --> Set velocities for moving towards and out of the cal switch (E0)

!rmvel --> Set velocities for moving towards and out of the rm switch (EE)

Additional differences when in extmode = 1:

If the pitch or gear parameter is changed, all parameters which are in revolutions/s (e.g. vel) are recalculated internally. So the axis velocities will remain the same.

joyvel --> The joystick velocity can (and has to be) set independently from **vel** by the **joyvel** instruction.

The **?lim** instruction, when requested without an axis specifier, now returns all limits in a correctly formatted way.

9.1.1 extmode (Switch to Extended Mode)

Syntax: `!extmode or ?extmode`

Parameter: `0 or 1`

Description: This instruction switches the TANGO controller into extended mode. This mode offers improved behavior and more instructions than the standard interpreter. For further information please refer to the **Extended Mode** Chapter 9.1.

0 = default, compatible interpreter mode

1 = extended interpreter mode

Response: currently used extmode, 0 or 1

Examples:

`!extmode 1` Set controller behavior to extended mode

`?extmode` Read extended mode setting

9.2. Scan Mode

In Scan Mode the controller executes move instructions with a vector velocity.

9.2.1 scanmode (Switch to Scan Mode)

Syntax: !`scanmode` or ?`scanmode`
Parameter: 0, 1 or 2

Description: This instruction switches the TANGO controller into scan mode, which may be used for continuous path control. This mode applies a constant vector velocity for automatic moves (`moa`, `mor`) which is set by '`scanvel`'.

0 = normal operation (default, no scan mode)
1 = scan mode 1
2 = scan mode 2

Scan mode 1:

- The resulting travel velocity of automatic moves is **scanvel**.
- The individual '**vel**' settings are ignored.
- Applies to single axis and vector moves, e.g. "`!moa x 10`", "`!moa 10 20`"

Scan mode 2:

- Similar to scanmode 1, but individually started axes now travel at their original '**vel**' settings. May be useful e.g. when the Z-axis controls the focus.
- The resulting travel velocity of a vector move is **scanvel**.
- The individual '**vel**' settings are used for single axis move. e.g. "`!moa z -10`"
- Applies to vector moves of 2 or more axes only, e.g. "`!moa 10 20`"

Response: Scanmode (automatic move mode) as integer

Examples:

```
!scanmode 1           Set controller into scanmode 1  
?scanmode            Read controller scanmode
```

```
!vel 20 20 10 "!scanvel 0.1" "!scanmode 2"  
!moa 50 100         (vector move with scanvel)  
!mor z 1.5          (single axis move executed with vel z: 10mm/s)
```

9.2.2 scanvel (Scanmode Vector Velocity)

Syntax: !`scanvel` or ?`scanvel`
Parameter: 0.000001 to 1000 [mm/s]

Description: This instruction sets or reads the '`scanmode`' vector velocity in millimeter per second. It is also used for the snapshot dissection mode (`sns` 3) continuous path velocity. There is only one parameter.

Response: Currently selected velocity in [mm/s]

Examples:

```
!scanvel 10         Set scanmode vector velocity to 10 mm/s  
?scanvel            Read scanmode velocity
```

9.3. ModuloMode

Modulo Mode can be used for turntable- and for endless rotating applications.

9.3.1 modulomode (Define Linear or Turntable Modes)

Syntax: !modulomode or ?modulomode

Parameter: x, y, z, a or none
0, 1, 2, 3 or 4

Description: This instruction sets or reads the axis modulo mode. Modulo mode switches the specified axes from linear into a turntable mode that remains within [0...360[° or [0...1[depending on '**dim**'. 1 linear and 4 turntable modes are available:

- 0 : Modulo Mode off (default mode, e.g. for linear axes)
- 1 : Travel shortest distance to target position
(automatically decides to travel forward or back)
- 2 : Only travel in positive direction
(may result in traveling up to one additional revolution)
- 3 : Only travel in negative direction
(may result in traveling up to one additional revolution)
- 4 : Do not travel over Zero
e.g. for swiveling axes <360° with limited operation range or as cable tear-off protection)

Modes 1,2 and 3 ignore the upper and lower limits of the axis. While mode 4 uses the limits (**cal,rm,lim**) in order to narrow the possible operating range.

Remarks: Modulo Mode 1, in conjunction with the !speed instruction, can be used to achieve an endless rotating mode (pump, fan, etc).

Response: Currently selected modulo mode

Examples:

```
!modulomode 0 0 1 (set Z axis to modulo mode 1, X and Y to standard linear mode)
!modulomode a 4 (set A axis to modulo mode 4)
?modulomode => 0 0 0 (returns modulo mode of all axes, e.g. 0s)
?modulomode x => 1 (returns modulo mode of X axis, e.g. 1)
```

10. Controller States and Error Messages

10.1. autostatus (Set Autostatus to required behavior)

Syntax: !autostatus or ?autostatus

Parameter: 0, 1, 2, 3 or 4

Description: Select auto response behavior for completion of move and calibration instructions. The power-on default is mode 1. Autostatus mode can not be saved by the **'save'** instruction.

- 0 : Disable automatic status replies
(Except **'save'** instructions will still return either "OK..." or "ERR")
- 1 : The Default.
Position reached response after each automatic move (moa, mor, cal, rm)
(a 5 character string with e.g. '@' for each configured axis is returned by the controller. Please also refer to **'statusaxis'** for further information. Autostatus 1 is the default configuration after power-on.
- 2 : The controller responds with the 'position reached' message of mode 1, plus the **status message** "OK..." or "ERR".
- 3 : A simple <CR> (0x0d hex) is returned to indicate that the move is completed. It can be used to improve performance for higher vector throughput, but contains less information e.g. concerning possible errors.
- 4 : Echoes the sent instruction including parameters.

Example: Assume a controller with 3 axes and autostatus set to 1. After completion of a move (moa, mor, m, a) the controller will return a 5 ASCII character string "@@@-." which means move completed.

```
!autostatus 0    Switch off autostatus ("statusaxis" has to be polled to find out if the axis moving or stopped)
!autostatus 1    Set autostatus to the default behavior
!autostatus 3    Set autostatus to <CR> response for low communication overhead
?autostatus      Read the currently selected autostatus
```

10.2. statusaxis (Read State of Axis)

Syntax: ?statusaxis or statusaxis or sa
Parameter: x, y, z, a or none

Description: Statusaxis responds the state of each axis.
 Similar to the '**autostatus 1**' response for move instructions,
 but with an additional '-' after the dot.
 It can be used for polling move states when in 'autostatus 0'
 mode, where no automatic response is generated.
 Every response except of 'M' means the axis has stopped for
 some reason and may be ready for a new move instruction.
 It is recommended to check the returned ASCII character for
 != 'M' (not equal to 'M', 0x4D hex).

Response: 6 ASCII characters: [STATUS X][STATUS Y][STATUS Z][STATUS A].-

@ => Axis is not moving and ready
M => Axis is moving
J => Axis is ready and may also be controlled manually (by joystick)
S => Limit switches are actuated and prevent further automatic move
A => ok response after cal instruction
D => ok response after rm instruction
E => error response, move aborted or not executed
 (e.g. **cal**, **rm** limit switch error or stop input active)
T => Timeout occurred (refer to '**caltimeout**' instruction)
- => Axis is not enabled, not available in hardware

Example: Assume ?statusaxis returns @@@-.-
 This means three axes are enabled and ready to move.

?statusaxis (JM--.- = 2 axis controller, X is ready, Y is moving)
sa (e.g. may return A@@-.- after calibrating the X-Axis)
sa x (e.g. may return M if axis is moving)

10.3. corrst (Read Position Correction State)

Syntax: ?corrst or corrst
Parameter: x, y, z, a or none

Description: Read the state of position correction
 Bit 0 (1) = correction data available
 Bit 1 (2) = correction requested (by '!corr 1')
 Bit 2 (4) = correction active

Response: Bit coded integer number

Example: corrst => 7 3 0
 Corrst x => 7 (Bit 0,1,2 are 1 = correction active)

10.4. status (Read the Controller Error State)

Syntax: ?status or status
Parameter: none

Description: The ?status instruction responds with the current state of the controller. Which is either 'OK...' or an 'ERR' with the error number. The error number description can be found in chapter **Error Numbers**. Also refer to '**err**' and '**help**' instructions.

Response: OK... or ERR with error number

Example: ?status => ERR 4
 ?status => OK...

10.5. err (Read Error Number)

Syntax: ?err or err, !err
Parameter: none

Description: The instructions err or ?err return the controller error state or 0, if no error occurred. The error state will be updated or re-set by the next instruction. If not a permanent error (like e.g. 29) the error state may be cleared to zero by sending !err.

Response: Error number as decimal value
 (refer to Chapter 5. "**Error Numbers**")

Example: err (may return a 0)
 ?err (same as err)
 !err (clear error state if no permanent error)

10.6. help (Read Error Number with Description String)

Syntax: ?help or help
Parameter: none or requested error number

Description: The instruction help returns a text string. It contains the error state with appended error description. The error state is not cleared to zero. Please also refer to the '**err**' instruction.

Called without a parameter:

It returns the controller's error state with description

Called with a parameter (error number):

It returns this error number with the corresponding comment

Response: Error number as decimal value, error description as ASCII text

Example: help => ERROR 0,no error (assuming there is no error)
 help => ERROR 5,number outside range
 help 29 => ERROR 29,servo amplifier off

10.7. service (Print Service Information to Terminal)

Syntax: ?service or service
Parameter: none

Description: The instruction service returns a multi-line parameter and state list of the controller. It may be used for debugging or in case of service requests. Either a terminal program or SwitchBoard version 1.19 and above can be used.

Response: Many lines of text including e.g. serial number, parameters, states etc. Each line terminated by a [CR].

Example: service

10.8. pci (Is PCI Bus)

Syntax: ?pci or pci
Parameter: none

Description: Check if the TANGO controller is used as PCI/PCI-E card (plugged into a PC slot).

0 = Controller is a desktop version
1 = Controller is a PCI or PCI-E card, plugged in the PCI(-E) slot of a computer (here: no RS232 or USB communication)

Response: 0 or 1

Example: pci => 0 (e.g. a TANGO Desktop)

10.9. isvel (Read Actual Velocities)

Syntax: ?isvel or isvel
Parameter: x, y, z, a or none

Description: Read the actual velocity(ies) at which the axis is currently traveling. Unlike '**?vel**' or '**?speed**' this instruction returns the currently traveled (true) speed of the axes, even when controlled by a HDI device.

Optional read-resolution: As an option to read the value with higher precision, the number of required decimal places can be specified with the query "**?isvel [0...16 decimal places]**". If no precision is defined, the default resolution is 3 decimal places.

Response: Actual axis velocity in [mm/s]

Example:

?isvel => Read actual velocity of all axes
?isvel y => Read actual velocity of the Y axis (e.g returns 10.000)
?isvel 4 => Read actual velocity of all axes with 4 decimal places (0.0000)
?isvel y 6 => Read actual velocity of the Y axis with 6 decimal places



10.10. maxpos (Maximum Position)

Syntax: ?maxpos

Parameter: x, y, z, a or none

Description: Read the maximum position value which the controller can accept due to internal limitations. It depends on e.g. the selected pitch, gear or motorsteps.

Response: Maximum position value of the axes
(unit depends on '**dim**' setting)

Example:

?maxpos => 2600.0000 2600.0000 2600.0000

?maxpos x => 2600.0000 (X axis accepts positions from -2600mm to +2600mm)

11. General Adjustments

With the following instructions the parameters of the controller are widely scalable to the given mechanic construction and to customer requirements. The controller is adaptable to the requested requirements.

11.1. dim (Unit for Positions and Velocities)

Syntax: !dim or ?dim
Parameter: x, y, z, a or none
 0 to 9

Description: The dim instruction sets the unit (here "dimension") of the input and output parameters related to length, e.g. position or move instructions. Dim 9 also sets the velocity parameters to mm/s (e.g. '**vel**', '**speed**'), which else remain in motor revolutions per second.

```
0  => Micro steps
1  => µm
2  => mm           (default, velocities in motor revolutions/s)
3  => 360°
4  => revolutions
5  => cm
6  => m
7  => inch
8  => mil
9  => mm          (difference to mode 2: all velocity units in mm/s)
```

Remarks: For dim 3 (=360°) and 4 (=revolutions) it is recommended to set the **spindle pitch** to 1mm.
 In dim mode 0 the Microstep resolution can be specified by the '**usteps**' instruction, in order to match the required amount of steps per revolution (e.g. 40000, 54000, 360).
 For positioning instructions as **!moa**, **!mor**, fractional values can also be used as the internal resolution (typ. 819200/rev) might be higher than the user set microsteps.

Response: Current dim settings

Examples:

```
!dim 4 1  set dim unit for X to [revolutions] and for Y to [µm]
!dim z 9  set dim unit for Z to [mm and mm/s]
!dim 2 2 2 set dim unit for axes X, Y and Z to [mm]
?dim     read dim unit for all axes
?dim a   read dim unit of A-axis only
```

11.2. pitch (Spindle Pitch)

Syntax: !pitch or ?pitch
Parameter: x, y, z, a or none
 0.0001 to 72 [mm/rev]

Description: This instruction sets or reads the spindle pitch which defines the axis travel distance in millimeter per motor (or gear) revolution.

Optional read-resolution: As an option to read the parameter with higher precision, the number of required decimal places can be specified with the query "?pitch [0...16 decimal places]". If no precision is defined, the default resolution is 4 decimal places.

Remarks: If the required pitch value is an infinite number due to a 1/x function, the '**gear**' parameter can be used instead or in combination.

Response: currently used spindle pitch in [mm per motor revolution]

Examples:
!pitch 4 1 set spindle pitch X=4[mm] and Y=1[mm]
!pitch z 28.895 set spindle pitch Z=28.895[mm]
?pitch read spindle pitch of all axes (e.g. returns 1.0000 1.0000)
?pitch a read spindle pitch of A-axis only
?pitch 9 read spindle pitch of all axes with 9 decimal places
?pitch y 6 read spindle pitch of Y-axis with 6 decimal places (1.000000)

11.3. gear (Gear Ratio)

Syntax: !gear or ?gear
Parameter: x, y, z, a or none
 0.001 to 1000

Description: This instruction sets or reads the axis gear ratio. If there is no gearbox mounted to the axis, this parameter should be left at its default value of 1.

Optional read-resolution: As an option to read the parameter with higher precision, the number of required decimal places can be specified with the query "?gear [0...16 decimal places]". If no precision is defined, the default resolution is 3 decimal places. Please also refer to the examples below.

Remarks: If the required pitch value is an infinite number due to a 1/x function, the '**pitch**' parameter can be used instead or in combination.

Response: currently used gear ratio

Examples:
!gear 10 set gear ratio X=1:10
!gear 4 1 set gear ratio X=1:4 and Y=1:1
!gear z 12.5 set gear ratio Z=1:12.5
?gear read gear ratio of all axes
?gear a read gear ratio of A-axis only (e.g. returns 1.000)
?gear 9 read gear ratio of all axes with 9 decimal places
?gear z 10 read gear ratio of Z-axis only with 10 decimal places

11.4. motorsteps (Motor Steps Per Revolution)

Syntax: !motorsteps or ?motorsteps

Parameter: x, y, z, a or none
[multiples of 4]

Description: This instruction sets the steps per revolution of the motor, which can be found in the datasheet. Common motors have 200 steps per revolution (1.8° full step). This is the TANGO default value. Other motors may have e.g. 400, 500 or 24 steps per revolution. It is essential for operation to have this parameter set according to the datasheet. The motor steps parameter must be a multiple of 4 in the range of 4 to 65534.

Response: Selected motorsteps of the stepper motor(s)

Examples:

```
!motorsteps 200 200 400      set motor steps for X and Y to 200 and Z to 400
!motorsteps x 500           set motor steps for X to 500
?motorsteps                 read motorsteps of all axes
?motorsteps a               read motorsteps of A-axis only
```

11.5. accel (Acceleration)

Syntax: !accel or ?accel
Parameter: x, y, z, a or none
0.0001 to 20 [m/s²]

Description: This instruction sets or reads the acceleration which is used for all moves, the speed instruction and manual control by HDI devices.

Optional read-resolution: As an option to read the parameter with higher precision, the number of required decimal places can be specified with the query “?accel [0...10 decimal places]”. If no precision is defined, the default resolution is 2 decimal places.

Remarks: In case of a stop event, **'stopaccel'** is used instead.

Response: Currently used acceleration in m/s²

Examples:

```
!accel 0.5      set acceleration X=0.5[m/s2]. Other axes are not affected
!accel 1 0.55   set acceleration X=1.0[m/s2] and Y=0.55[m/s2]
!accel z 0.2    set acceleration Z=0.2[m/s2]. Other axes are not affected
?accel         read all axes for their current acceleration
?accel z       read Z axis for its acceleration
?accel 6       => 0.500000 0.123456 0.200000
?accel y 4     => 0.1235
```

11.6. accelfunc (Acceleration Ramp Function)

Syntax: !accelfunc or ?accelfunc
Parameter: x, y, z, a or none
0, 1 or 2

Description: Select the acceleration ramp type for automatic moves (e.g. m, moa, mor, moc, cal, rm).

0 = Linear acceleration/deceleration ramp
1 = sin² acceleration/deceleration ramp
2 = reserved, currently same as 1: sin²

Remarks: The acceleration ramp for **'go'** and **'speed'** instructions and manual control (HDI) always remains linear accelerated.

Response: Currently used acceleration type

Examples:

```
!accelfunc 1    set accel function X to sin2, other axes are not affected
!accelfunc x 1  set accel function X to sin2, other axes are not affected
!accelfunc 1 1 0 set accel function in X and Y to sin2, Z to linear accel.
?accelfunc     read acceleration ramp function of all axes
?accelfunc z   read acceleration ramp function of Z axis only
```

11.7. stopaccel (Emergency Stop Deceleration)

Syntax: !stopaccel or ?stopaccel

Parameter: x, y , z, a or none
0.001 to 200 m/s²

Description: This instruction sets the deceleration for emergency stop conditions. It will be used by:

- abort instructions
- active stop input
- a '**cal**' or '**rm**' move (at the limit switch)
- when detecting an unexpected limit switch

Optional read-resolution: As an option to read the parameter with higher precision, the number of required decimal places can be specified with the query "?stopaccel [0...10 decimal places]". If no precision is defined, the default resolution is 2 decimal places.

Response: Deceleration for stop conditions

Examples:

```
!stopaccel 1 1 2 Set the stop deceleration for X and Y to 1 and Z to 2 [m/s2]  
!stopaccel x 1.5 Set the X stop deceleration to 1.5[m/s2]  
?stopaccel Returns the stop deceleration of all axes  
?stopaccel z Returns the stop deceleration of Z axis only (e.g. 1.50)  
?stopaccel 6 Returns stop deceleration of all axes with 6 fractional digits  
?stopaccel z 9 Returns stop deceleration of Z axis with 9 fractional digits
```

11.8. vel (Velocity)

Syntax:	!vel or ?vel
Parameter:	x, y , z, a or none 0.000001 to 200 [rev/s] (or up to 3000 [mm/s] if dim = 9)
Description:	Velocity for automatic moves, cal**, rm** and HDI** Except of dim=9 the unit is always motor revolutions per second. In dim=9 the unit is [mm/s]. Optional read-resolution: As an option to read the parameter with higher precision, the number of required decimal places can be specified with the query "?vel [0...16 decimal places]". If no precision is defined, the default resolution is 3 decimal places.
Remarks: **	If extmode =0 (default), vel is also used for - the HDI (joystick) velocity - the cal and rm instructions extmode =1 provides separate parameters (joyvel, calvel, rmvel). The velfac instruction can be used in addition to vel, but is not necessary or recommended.
Response:	Currently selected velocity
Examples:	
!vel 1.0 15	set velocity X=1[revolution/s] and Y=15[revolution/s]
!vel z 0.1	set velocity Z=0.1[revolution/s]
?vel	read velocity of all axes
?vel x	read velocity of X axis only
?vel 6	=> 20.000000 0.123456 5.000000
?vel y 4	=> 0.1235

11.9. velfac (Velocity Factor)

Syntax: !velfac or ?velfac
Parameter: x, y , z, a or none
 0.01 to 1.00

Description: This instruction sets or reads the velocity factor, which is used for all consecutive automatic moves. It is internally multiplied to the velocity (vel).

Response: Currently used velocity factor [0.01 to 1.00]

Examples:
?velfac read velocity factor of all axes
?velfac z read velocity factor of Z axis only
!velfac x 0.1 set velocity factor of X axis to 1/10 of specified velocity
!velfac 1 1 1 set velocity factor of X,Y,Z to specified velocity (default)

11.10. secvel (Secure Velocity)

Syntax: !secvel or ?secvel
Parameter: x, y , z, a or none
 0.000001 to 100 [mm/s]

Description: The security speed limitation is used as long as the axis is not calibrated and range measured ('cal', 'rm'). The unit is always mm/s and does not depend on the 'dim' setting. It is intended to prevent mechanical damage as long as the controller does not know the mechanical limits of the axis. (The breaking distance behind the hardware limit switches often is not sufficient to stop the axis under all velocities).

Setting this parameter to higher values may also be used as a workaround at own risk, if executing a cal/rm is not wanted. Axes which only have one (E0/cal) or do not provide any limit switch (refer to '**swact**' settings) disable the security speed limit after a cal or do not even apply the limit.

Optional read-resolution: As an option to read the parameter with higher precision, the number of required decimal places can be specified with the query "?secvel [0...16 decimal places]". If no precision is defined, the default resolution is 2 decimal places.

Response: Currently used secure velocity in [mm/s]

Examples:
!secvel 100 100 100 => Set maximum possible velocity of X Y Z
!secvel y 14.5 => Set maximum possible velocity of Y to 14.5 mm/s

11.11. cur (Motor Current)

Syntax: !cur or ?cur
Parameter: x, y, z, a or none
0.03 to [maximum current]

Description: This instruction sets or reads the motor current. The maximum current is limited by hardware or additionally by factory settings (ETS) and may be checked using '**maxcur**' instruction.

Remarks: Please check the motor datasheet first in order not to destroy the motor by overcurrent/overtemperature. Also, if the motor current set too low it can cause the axis to move incorrectly and lead to mechanical damage. At least for open loop systems (without encoder feedback) it is required to ensure the axis can travel under all required velocities and load situations.

Response: Motor current in Ampere (e.g. 1.00)

Examples:
!cur 1.1 set X motor current to 1.1[A]
!cur 1 2 set motor current for X=1[A] and Y=2[A]
!cur z 0.3 set Z motor current to 0.3[A]
?cur read motor current of all axes
?cur x read motor current of X axis only

11.12. reduction (Motor Current Reduction Factor)

Syntax: !reduction or ?reduction

Parameter: x, y, z, a or none
0 to 1.00

Description: Motor current reduction factor when idle, used to reduce the dissipated heat from the motor.
When the axis is idle (stopped), the motor current (**cur**) is reduced by this factor.
Floating point numbers from 0 to 1.00 represent 0 to 100% of the motor current. Reduction is disabled when set to 1 (default).

Remarks: The current reduction can be delayed by the '**curdelay**' instruction.
Without a delay, reduction might have a slight impact on vector throughput, as it takes some extra time reduce and increase the current after and ahead of each move instruction. While reducing, the axis might also show slight "waggle", depending on mechanical load.

In systems with encoders: Reducing the current to less than 0.3 (30%) will disable the permanent **closed loop** while reduction is active (axis stopped and **curdelay** expired).

Response: Reduction factor(s) [0.00 to 1.00]

Examples:

```
!reduction .3 .7 Set idle current reduction X=0.3*cur[A] and Y=0.7*cur[A]
!reduction 1 1 1 Disable reduction for axes X,Y,Z
!reduction z 0.5 Set Z idle current reduction factor to 0.5*cur[A]
?reduction Read idle current reduction factor of all axes
?reduction x Read idle current reduction factor of X axis only (e.g. 1.00)
```

11.13. curdelay (Delay for Current Reduction)

Syntax: !curdelay or ?curdelay

Parameter: x, y, z, a or none
0 to 65000 [ms]

Description: At the end of each move the axis enters the idle state. If the motor current **reduction factor** is set to a value less than 1.0 this reduction will take effect after the **curdelay** time.

Remarks: A delay might be necessary in cases of
- long time exposure (to avoid waggle)
- high vector throughput (to avoid reduction between the move)
- heat reduction when not operating (as a "savesaver")

Response: Selected delay time for the current reduction in [ms]

Examples:

```
!curdelay 100 450 Set delay for motor current reduction X=100[ms] and Y=450[ms]
!curdelay z 15000 Set delay for motor current reduction Z=15 seconds
!curdelay 0 0 Set immediate reduction for X and Y axis
?curdelay Read motor current reduction delay of all axes
?curdelay x Read motor current reduction delay of X axis only
```



11.14. ecomove (EcoMove Current Level)

Syntax: !ecomove or ?ecomove

Parameter: x, y , z, a or none
0 to 70

Description: EcoMove reduces the motor current while the axis travels at constant velocity. Like "**reduction**" it can be used to greatly reduce the dissipated heat of the motor. But the EcoMove parameter works in a different way: Greater values = greater power saving, which means a eco level value of 0 is 100% current and a eco level of 30 is 70% current.

0 = Full motor current (default)

70 = Maximum power saving level (low motor heating and force)

Response: EcoMove level

Examples: !ecomove 0 0 0 0 (disable ecomove for all axes / 0%)
!ecomove x 25 (reduce X current by 25% when moving)
?ecomove (return all ecomove levels)

11.15. axis (Enable, Disable, Switch Off Axis)

Syntax: !axis or ?axis
Parameter: x, y, z, a or none
-1, 0, 1

Description: This instruction enables, disables and switches off axes. The currently selected state can also be read.
A disabled axis still powers the motor with its current, while a switched off axis loses its torque.

1 = enabled
0 = disabled
-1 = axis power stage off

Response: Axis enable state

Examples:
!axis 1 1 1 1 enable all axes
!axis 1 0 1 0 disable Y and A axis, enable X and Z
!axis y -1 switch off Y axis: power stage Y off
?axis x read axis state of X axis only
?axis read axis state of all axes

11.16. axisdir (Axis Direction)

Syntax: !axisdir or ?axisdir
Parameter: x, y, z, a or none
0 or 1

Description: Travel direction of the axes.

0 = Normal axis direction
1 = Reversed axis direction

Remarks: Changing the axis direction should only be used once as a general setup of the hardware direction, and not be used during normal operation.

The hardware limit switches CAL and RM will automatically be reassigned when switching the axis direction. Also swact, swpol, swtyp, readsw etc. Exception: The 'swin' function is not affected.

Closed loop will be deactivated when changing the direction and has to be reenabled by cal or reset/power-on.

If the axis is position corrected by factory, a change of the axis direction will lead to inaccuracy.

Response: Axis direction

Examples:
!axisdir 0 1 0 1 Reverse travel directions of Y and A axis
!axisdir z 1 Set reverse travel direction for Z axis
?axisdir Read axis direction of all axes
?axisdir x Read axis direction of X axis only

11.17. motortable (Motor Correction Table)

Syntax: !motortable or ?motortable
Parameter: x, y, z, a or none
0 or number specified by factory

Description: This instruction adds a motor correction, which can be used to reduce resonances and vibration. The motor has to be measured for the specific application by factory. Then a table number will be assigned and the customer may activate it by setting the corresponding motortable number. Using a wrong motortable will lead to increased noise and position error.

0 = No correction

Response: Currently used motortable(s)

Examples:
!motortable 1 1 2 0 Select motortable 1 for X and Y, 2 for Z and no for A
!motortable x 0 Disable correction for x
?motortable Read the currently used tables for all axes

11.18. usteps (Microstep Resolution)

Syntax: !usteps or ?usteps
Parameter: 360 ... 1638400

Description: This instruction sets the microsteps for one motor revolution, used in axis unit "**dim 0**" (Microsteps). It offers compatibility to application software that is written for e.g. 40000 or 54000 microsteps. One value applies to all axes that have **dim 0** selected.

Remarks: For positioning (moa, mor etc.) in microsteps dim mode 0, the microstep position can also be specified with fractional digits (e.g. !mor 40000 4500 0.5).

Response: Currently used **dim 0** microstepping resolution in [steps/rev]

Examples:
!usteps 40000 Set microstep resolution to 40000/revolution (for dim=0)
?usteps Read the microstep resolution

11.19. resolution (Position Number Format)

Syntax: !resolution or ?resolution
Parameter: 0, 1, ... 6

Description: This instruction sets the resolution of '?pos' and similar position returning instructions for **dim 1, 2 and 9**. It affects the amount of returned decimal places, as listed below. One value applies to all axes, default = 4 (100nm resolution).

Value	Resolution dim 2,9	Resolution dim 1
0	= 1mm	0.1 μ m
1	= 0.1mm	0.1 μ m
2	= 0.01mm	0.1 μ m
3	= 0.001mm	0.1 μ m
4 (default)	= 0.0001mm	0.1 μ m
5	= 0.00001mm	0.01 μ m
6	= 0.000001mm	0.001 μ m

Affected instructions are: ?pos, ?lim, ?maxpos, ?posclr, ?distance, ?twi, ?ctrs, ?ctrdiff, ?caliboffset, ?rmoffset, ?calpos, ?trigd, ?snsa, ?sntp.

Response: Responded decimal places for the 'pos' and other position returning instructions.

Examples:

```
!resolution 5      Set position read resolution to 10 nm (5 decimal places if mm)
                   e.g. "?pos x" returns 0.00000 in dim 2 and 9, 0.00 in dim 1.
?resolution        Read the resolution of
```

11.20. backlash (Mechanical Backlash Compensation)

Syntax: !backlash or ?backlash
Parameter: x, y, z, a or none
-100.0 ... 100.0 [μ m]

Description: Compensate mechanical backlash of the axis.
Unit is micrometer [μ m], independent from dim.

Mechanical backlash becomes visible when traveling to a position from both directions (forward and backward).

0 = Backlash compensation off

Remarks: Backlash compensation is not applied when in **closed loop mode**.

Response: Currently used backlash in μ m

Examples:

```
!backlash 12.7 21.3 0  Set backlash for X to 12.7 $\mu$ m, Y=21.3 $\mu$ m and Z=none
!backlash x 0          Disable backlash compensation for X
!backlash x 5          Compensate a backlash of 5 $\mu$ m in X
?backlash              Read the backlash compensation value of all axes
?backlash z           Read the backlash compensation value of Z axis only
```

11.21. lock (Select Parameters to Lock)

Syntax: ?lock or !lock
Parameter: 0 to 15, 0 or 1

Description: Select write protection for TANGO parameters (lock state).
Either bitwise: !lock [bit number] [0 or 1]
or multi bits : !lock [bit field of 0s and 1s]
After selecting the parameters to lock, these have to be
applied to the desired axes by '**lockaxis**'.

Response: Specified lock bit state or entire lock bit field, LSB first.
The bit positions represent the following parameters:

Bit Nr.	Parameter
0:	Pitch
1:	Gear
2:	Cur
3:	MotorSteps
4:	SwPol
5:	SwTyp
6:	SwDir
7:	EncTTL
8:	EncPeriod
9:	AxisDir
10:	MotorTable
11:	BackLash
12:	Anglecorr
13:	CalLrnPos

Example: !lock 111 => Set lock bits 0 1 and 2, leave others unaffected
 !lock 2 0 => Clear lock condition for parameter 2 (=current)
 !lock 0 1 => Set lock bit for parameter 0 (pitch)
 ?lock => Read lock bit field (e.g. "0000000000000000")
 ?lock 5 => Read lock bit #5 state

11.22. lockaxis (Apply the Parameter Lock to Axes)

Syntax: ?lockaxis or !lockaxis
Parameter: x, y , z, a or none

Description: Apply the parameter lock, selected by the '**lock**' instruction,
to the specified axes. If the lockbits or lockaxis are zero
nothing will be locked.

Response: Axes to which the lock bits are currently applied.

Example: !lockaxis y 1 => Apply lock bits to Y axis
 !lockaxis 1 1 => Apply lock bits to X and Y axis
 ?lockaxis x => Read if lock bits are applied to the X axis
 ?lockaxis => Read all axes (returns e.g. "1 1 0 0")

11.23. lockstate (Read all internal Lock States)

Syntax: ?lockstate

Parameter: x, y, z, a or none

Description: Set/read the internal parameter write protection (lock) state caused by the ETS (factory) and user lock/lockaxis settings. The bit positions represent the following parameters:

Bit Nr.	Parameter
0:	Pitch
1:	Gear
2:	Cur
3:	MotorSteps
4:	SwPol
5:	SwTyp
6:	SwDir
7:	EncTTL
8:	EncPeriod
9:	AxisDir
10:	MotorTable
11:	BackLash
12:	Anglecorr
13:	CalLrnPos

Response: Lock state as 16 bits ASCII string(s), 0s and 1s, LSB first

Example: ?lockstate => Read lock state of all axes
?lockstate x => Lock state of X axis e.g. "1100000000000000"

11.24. stout (Select Status Signal Output)

Syntax: !stout or ?stout

Parameter: 0,1,2,3,4

Description: Makes the state of the TANGO Status LED available to the optional AUX-I/O connector:

- 0 = Just Status LED, no AUX-I/O used (Standard)
- ~~1 = AUX-I/O Pin 5 (TAKT_OUT) may not be available!~~
- 2 = AUX-I/O Pin 6 (VR_OUT)
- 3 = AUX-I/O Pin 7 (SHUTTER_OUT)
- 4 = AUX-I/O Pin 8 (TRIGGER_OUT)

Remarks: To turn off the Status LED, instruction 'noled' may be used.

Response: Selected status output mode

Example: !stout 0 => Only use Status LED (default)
?stout => Read status output mode (returns 0,1,2,3 or 4)

11.25. noled (Select Status Signal Output)

Syntax: !noled or ?noled
Parameter: 0 or 1

Description: Set TANGO Status LED to "used" or "forced off".
Forcing the LED off may be necessary in low light applications
where no external light source is wanted.

0 Normal operation, Status-LED on (default)
1 Status-LED permanently off

Response: Status LED mode

Example: !noled 1 => Force Status-LED permanently off
 !noled 0 => Status-LED normal operation (default)
 ?noled => Read status output mode (returns 0 or 1)

11.26. updelay (Power Up Delay)

Syntax: !updelay or ? updelay
Parameter: -5000 to 5000

Description: Delay time of the TANGO controller on power up in [ms].

This parameter is ment for fixing problems of TANGO PCI/PCI-E
card versions with external power supply or long PCI reset
times of the computer mainboard.

Applications:

Use negative values to wait for valid motor voltage (e.g. when
using master-slave power switches for the external power
supply).

Use positive values to wait a fixed time (e.g. when the
mainboard generates a too long reset signal it causes the PCI
card to start as a Desktop version. So the COM port is not
accessible.)

Positive values: The controller waits for the specified time.

Negative values: The controller waits for valid motor voltage
for a maximum of this time or shorter.

Response: Power up delay time in [ms]

Example: !updelay -2000 => Wait max. 2s for valid motor voltage level
 !updelay 2500 => Wait 2.5s extra on power up
 ?updelay => Read the power up delay

12. Limit Switch Instructions (Hardware and Software)

12.1. lim (Software Limits)

Syntax: `!lim or ?lim`
Parameter: `x, y, z, a or none`
`+-maximum position range (unit depends on 'dim')`

Description: This instruction sets or reads the movement range limitations. The upper and lower software limits must send together in a single `!lim` instruction. The position unit depends on the `'dim'` setting.

Remarks: In **Extended Mode** (`extmode = 1`) the `'?lim'` instruction returns the limits as a correctly formatted string, as shown in the example below.

Response: `Currently used software limits [lower] [upper]`

Examples:

```
!lim -1000 1000 -2000 2000    set the software limits for X and Y
!lim z -500 1700             set the software limits for Z
!lim z -45.37                set the lower software limit of Z
?lim y                       read software limits of Y-axis only
?lim                         read software limits of all axes
                             only recommended in extmode=1, as shown below:
```

`?lim response example for 3 axes in`
`--> extmode=0: -1000 1000, [CR]-1000 1000, -1000 100[CR]`
`--> extmode=1: -1000 1000 -1000 1000 -1000 100[CR]`

12.2. limctr (Enable or Disable Limit Control)

Syntax: `!limctr or ?limctr`
Parameter: `x, y, z, a or none`
`0 or 1`

Description: This instruction enables or disables the limit control or returns the current state of it.

Attention: If limit controls are disabled, the controller doesn't care about limits, which may cause mechanical damage! Limit control is enabled by default from power on.

`0 = disabled`
`1 = enabled (default)`

Response: `Limit control state`

Example:

```
!limctr y 0                 disable Y limit control, Y axis limit switches are ignored
!limctr 1 1 1              enable X, Y and Z limit control
!limctr z 1                enable Z limit control
?limctr a                  read limit control state of A axis only
?limctr                    read limit control state of all axes
```

12.3. nosetlimit (Do not set limits by cal/rm)

Syntax: !nosetlimit or ?nosetlimit
Parameter: x, y, z, a or none
 0 or 1

Description: Enables or disables the setting of software limits by the calibration (**cal**) and range measure (**rm**) functions. The default is nosetlimit=0 which means that the software limits are set by the cal/rm moves to these min/max positions.

Response: 0 = set software limits to !cal and !rm positions (default)
 1 = do not change software limits after !cal or !rm

Examples:
!nosetlimit 1 1 X and Y axis do not take software limits after !cal and !rm
!nosetlimit y 1 Y axis is does not set software limits of !cal and !rm move
?nosetlimit read nosetlimit state of all axes
?nosetlimit a read nosetlimit state of A axis only

12.4. swtyp (Type of Limit Switch)

Syntax: !swtyp or ?swtyp
Parameter: x, y, z, a or none
 0 or 1

Description: Set or read the type of the limit switches. The sequence is [E0] [REF] [EE] for all axes. The [REF] switch is not used by the TANGO controller.

Remarks: When using no axis parameter (x,y,z or a), the 3 values will be used for all axes! To set individual axes, please do this separately, use the axis parameter x,y,z or a. Please note that the E0 and EE switches are reassigned by a change of the '**axisdir**' instruction.

0 = PNP, which adds a pull-down resistor to the switch input
1 = NPN, which adds a pull-up resistor (default)

Response: Currently selected limit switch type

Examples:
!swtyp z 0 0 1 Set Z axis limit switches E0=PNP, REF(don't care), EE=NPN
?swtyp y Read switch types of Y axis

!swtyp 1 0 1 Set all! limit switches to NPN type (not recommended)
?swtyp Not recommended,
 in extmode=0 returns e.g. 1 1 11 1 11 1 1
 in extmode=1 returns e.g. 1 1 1 1 1 1 1 1 1

12.5. swpol (Polarity of Limit Switch)

Syntax: !swpol or ?swpol
Parameter: x, y, z, a or none
 0 or 1

Description: Set or read the polarity of the limit switches.
 The sequence is [E0] [REF] [EE] for all axes.
 The REF switch is not used by the TANGO controller.
 Important: When using no axis parameter (x,y,z or a), the 3
 values will be used for all axes! To set individual axes,
 please do this separately, use the axis parameter x,y,z or a.
 Please note that the E0 and EE switch are reassigned by the
 '**axisdir**' instruction.

0 = switch has active low signal
1 = switch has active high signal

Response: Polarity of the limit switches

Examples:

```
!swpol y 1 1 1     set polarity of Y limit switches (E0 REF EE) to positive edge
!swpol z 0 0 0     set polarity of Y limit switches (E0 REF EE) to negative edge
!swpol 1 0 1       set polarity of limit switches (E0 REF EE) for all axes
?swpol a           read limit switch polarity of the A axis
```

12.6. swdir (swap assignment of cal and rm switch)

Syntax: !swdir or ?swdir
Parameter: x, y, z, a or none
 0 or 1

Description: Swap the cal(E0) and rm(EE) switch assignment.

0 = switches are not swapped (default)
1 = switches are swapped

In opposite to the axisdir instruction, which swaps motor direction and limit switch assignment, swdir only swaps the switches E0<->EE without changing the axis direction. This may become necessary due to wiring of the axis and depends on the axis hardware. It is independent of axisdir, which works with and without a swapped swdir.

Attention: swdir should only be used to compensate different wiring of the stage limit switches. **Swapping the switches to the wrong assignment may result in mechanical damage!**

Response: Current state of endswith assignment(s)

Examples:

```
!swdir 1 1 0       Swap E0<->EE switch assignment in X and Y, not in Z
!swdir x 1          Swap E0<->EE switch assignment in X (E0 switch is now EE etc.)
?swdir              Read switch assignment of all axes
?swdir z            Read switch assignment of Z axis only
```

12.7. swact (enable or disable limit switches)

Syntax: !swact or ?swact
Parameter: x, y, z, a or none
 0 or 1

Description: This instruction enables or disables the limit switches.
 The sequence is always:

E0 REF EE

0 = switch is inactive (actuation state is ignored)
1 = switch is active

The REF switch is not used by the TANGO controller.
Disabling limit switches may damage the hardware.
When using no axis parameter, the 3 values will be used for all axes! To set individual axes please do this separately, use the axis parameter x, y, z or a.
Inactive switches always return a non actuated state when using '?readsw', while the 'swin' instruction still returns the switches TTL logic level.
Please note that the hardware E0 and EE switches are reassigned by the 'axisdir' instruction.

Remarks: If all switches of an axis are set to inactive, 'secel' will not be applied (no velocity limitation at all). If EE (rm) switch is set to inactive, the secel limitation will be released after the cal. If both switches E0+EE are activated, cal+rm must be executed in order to release the secure velocity.

Response: Limit switch enable states [E0] [REF] [EE] (e.g. 1 0 1)

Examples:
!swact 1 0 1 Enable cal and rm limit switches for all axes (REF disabled)
!swact z 1 0 1 Set Z limit switches E0=enabled REF=disabled EE=enabled
?swact a Read limit switches enable state of A axis only



12.8. readsw (Read Status of Limit Switches)

Syntax: ?readsw or readsw
Parameter: none

Description: Readsw returns the actuation state of the limit switch (while swin returns the signal level). Also readsw exchanges the E0 and EE switch assignment (cal direction is always E0) depending on 'axisdir'. Disabled switches (swact) are read as 0.

0 = limit switch is currently not actuated or disabled
1 = limit switch is currently actuated (axis is in switch)

Please note that the switch state is only valid when the swtyp, swpol parameters are set correctly and the switch is activated by swact.

Sequence of the 12 characters is:

Axis: X Y Z A X Y Z A X Y Z A
Switch: [E0][E0][E0][E0][Ref][Ref][Ref][Ref][EE][EE][EE][EE]

E0 = lower limit switch (!cal instruction)
Ref = Reference switch
EE = upper limit switch (!rm instruction)

Response: Actuation state of limit switches as 12 character ASCII string

Examples: readsw => 000000001000
(read all limit switch actuation states, EE of X is actuated)

12.9. swin (Read Limit Switch Input Level)

Syntax: ?swin or swin
Parameter: none or 0...7

Description: This instruction reads the limit switch signal directly. The response is a string of 8 characters, either 0 or 1.

0 = limit switch input signal is TTL low
1 = limit switch input signal is TTL high

In opposite to the "readsw" instruction, swin reflects the TTL input levels. Also disabled switches are represented with their current TTL input signal level. Swin is not affected by axisdir setting (does not exchange E0 and EE switches). The Ref signals are not used.

Sequence of the 8 characters is:

Axis: X Y Z A
Switch: [E0][EE][E0][EE][E0][EE][E0][EE]
Index : 0 1 2 3 4 5 6 7
E0 = lower limit switch (!cal)
EE = upper limit switch (!rm)

Response: Limit switch input TTL level as 1 or 8 ASCII characters

Examples: swin => 11111111 (read all 8 limit switch signal levels)
swin 1 => 1 (read EE of X Axis signal level)

12.10. statuslimit (Cal / Rm / Lim Status)

Syntax: ?statuslimit or statuslimit
Parameter: none

Description: Status of the soft- and hardware limits concerning the **cal**, **rm** and **lim** instructions.

The status information is arranged in 4 groups.

The character string positions are:

```
0 ... 3: Group 1 => cal state of axis 0-3 (x,y,z,a) '-' or 'A'  
4 ... 7: Group 2 => rm state of axis 0-3 (x,y,z,a) '-' or 'A'  
8 ... 11: Group 3 => lower soft limit state of axis 0-3 (x,y,z,a) -,L  
12 ... 15: Group 4 => upper soft limit state of axis 0-3 (x,y,z,a) -,L
```

The characters represent the state with 4 possible characters:

- => cal or rm not performed, limit not set/modified since power on

A => axis is calibrated (!cal)

D => axis is range measured (!rm)

L => software limit has been modified by (!lim)

STRING: "-----" up to max. "AAAADDDDLLLLLLLL"

AXIS : xyzaxyzaxyzaxyza

LIMIT : CAL RM LIM-LIM+

Response: ASCII string of 16 characters

Example: Assume '?statuslimit' returns the string "AA-A---D-LL-L--L"

This means in detail:

```
[ 0] A -> X-axis is calibrated  
[ 1] A -> Y-axis is calibrated  
[ 2] - -> Z-axis is not calibrated  
[ 3] A -> A-axis is calibrated  
[ 4] - -> X-axis is not range measured  
[ 5] - -> Y-axis is not range measured  
[ 6] - -> Z-axis is not range measured  
[ 7] D -> A-axis is range measured  
[ 8] - -> X-axis lower software limit is not modified  
[ 9] L -> Y-axis lower software limit is modified  
[10] L -> Z-axis lower software limit is modified  
[11] - -> A-axis lower software limit is not modified  
[12] L -> X-axis upper software limit is modified  
[13] - -> Y-axis upper software limit is not modified  
[14] - -> Z-axis upper software limit is not modified  
[15] L -> A-axis upper software limit is modified
```

13. Calibration and Range Measure Instructions

After power on or '!reset' of the controller, a calibration (instruction **!cal**) followed by a range measure (instruction **!rm**) should be executed in order to set the axis origin and hardware position limits.

From then on the controller will stop the axes automatically at the end of the available positioning range. It also disables the secure travel speed limitation of '**secvel**', which else is applied to protect the axes from possible damage.

The cal/rm instructions set the limits close to the limit switch positions. An additional position offset for the these limits can be specified with the instructions **!caliboffset** and **!rmoffset**.

Long axes and/or slow velocities may exceed the default calibration timeout of 40 seconds. Therefore the timeout can be set to the desired value by **caltimeout**. Please also refer to the optional **extmode** enhancements and **calmode** options for calibration. If a valid cal or rm was performed can be checked by **?statuslimit**.

13.1. cal (Perform Calibration to lower Limit Switch)

Syntax: !**cal** or **cal**
Parameter: **x**, **y**, **z**, **a** or none

Description: This instruction moves either the specified or all axes towards lower positions until the limitswitch E0 is detected. If the corresponding switch is disabled (swact), cal will not be performed.
The behavior of CAL depends on the setting of '**extmode**'.

Extmode=0 (mostly the default setting):

- CAL travels towards switch with the axis velocity '**vel**'
- CAL travels out of switch with '**calbspeed**'

Extmode=1:

- CAL travels towards switch with '**calvel**' parameter 1
- CAL travels out of switch with '**calvel**' parameter 2

The movement stops slightly ahead of the position where the switch was released. If required this travel distance can be increased by specifying a '**caliboffset**'.

Depending on the '**calmode**' setting this position is used as origin (position 0) and if '**nosetlimit**' is set to 0 (default) also as the new "lower software limit".

Remarks: The calibration status can be read by checking '**statuslimit**'. Highest repeatability (in combination with MR encoders only) can be achieved by teaching a precise '**callrn**' position.

Response: **Autostatus** dependent, similar to !moa, !mor etc. but instead of the '@' the axis status return string contains an '**A**' after a successful calibration or '**E**' if an error occurred (cal was unsuccessful) '**T**' if a timeout occurred (cal was unsuccessful) '- ' the axis is not present

Examples:

```
!cal                   execute a calibration for all enabled axes => "AAA-."  
cal y                  execute a calibration for Y axis           => "@A@-."
```

```
This sequence calibrates the X and Z axis => "A@A-."  
"!axis 1 0 1"  
"!cal"  
"!axis 1 1 1"
```

13.2. rm (Perform Range Measure to upper Limit Switch)

Syntax: !rm or rm

Parameter: x, y, z, a or none

Description: This instruction moves either the specified or all axes towards higher positions until the limitswitch EE is detected. If the corresponding switch is disabled (swact), rm will not be performed.
The behavior of RM depends on the setting of 'extmode'.

Extmode=0 (mostly the default setting):

- RM travels towards switch with the axis velocity 'vel'
- RM travels out of switch with 'calbspeed'

Extmode=1:

- RM travels towards switch with 'rmvel' parameter 1
- RM travels out of switch with 'rmvel' parameter 2

The movement stops slightly under the position where the switch was released. If required this travel distance can be increased by specifying a 'rmoffset'.

Depending on 'nosetlimit' (=0, default) also as the new "upper software limit" is set.

Remarks: The rangemeasure status can be read by checking 'statuslimit'.

Response: **Autostatus** dependent, similar to !moa, !mor etc. but instead of the '@' the axis status return string contains an 'D' after a successful rangemeasure or 'E' if an error occurred (cal was unsuccessful) 'T' if a timeout occurred (cal was unsuccessful) '-' the axis is not present

Examples:

```
!rm          execute a range measure for all enabled axes => "DDD-."
rm y        execute a range measure for Y axis           => "@D@-."
```

Or the sequence

```
"!axis 1 0 1"
```

```
"!rm"
```

```
"!axis 1 1 1"
```

range measure the X and Z axis, while Y is not used => "D@D-."

13.3. vrm (Virtual Range Measure)

Syntax: !vrm or vrm

Parameter: x, y, z, a or none
Axis length(s) in user **dim**

Description: Can replace the need of an **rm** move, by just defining the axis length without axis travel (time saving).

Same as with the **rm** instruction the

- SecVel is released
- corresponding statuslimit 'E' entry is set
- hardware limit is set

Vrm requires that **!cal** was performed on the axis.
Vrm does not return any autostatus reply (like the @@@-).

Warning: Specifying a wrong axis length can cause mechanical damage.

Remarks: Check **?err** response or **statuslimit** for 'E' entries to make sure the parameters were accepted.

If axes are not **calibrated** the vrm function causes error 2.

Axes with MR encoders (nanoScale) should always perform a true Rm for high accuracy measurement.

Vrm can also be used before executing an **rm** move in order to travel fast (without **secvel** limitation) near the **rm** limit switch → then **rm** can be executed (caution: velocity might be high now) to get the real maximum hardware travel range and/or to allow the above mentioned encoder autoadjust which is performed during **rm**. [Example #3]

Response: None

Examples:
vrm 75 50 virtual range measure (define axis lengths of X=75, Y=50)
vrm y 150 virtual range measure for Y axis (define Y=150)

Sequence example1:
cal x
cal y
cal z
?statuslimit => "AAA-----"
vrm 300 300 20
?statuslimit => "AAA-DDD-----"

Sequence example2:
cal x
cal y
!moa 10 10
!pos 0 0 (the lower limit is now at position -10 -10)
vrm 300 300 (the upper limit is set to 290 290)

Sequence example3:
cal x (calibrate the X axis)
!vel 40 (set X velocity to e.g. 40mm/s)
vrm 300 (virtually set X rm for e.g. a 300mm axis)
!moa 300 (move to end of X travel range without secvel)
!vel 10 (slow down for executing rm)
!rm x (perform true hardware rm from here=time saving)

13.4. calmode (Closed Loop/Calibration Behavior)

Syntax: !calmode or ?calmode

Parameter: x, y, z, a or none
0, 1 or 2

Description: This instruction reads or sets the closed loop behavior on power-up and also affects the calibration behavior:

0 = Cal instruction sets the zero position (default setting)
Closed loop enabled after cal move

1 = the power-up position remains the zero position even after calibration
Closed loop is enabled from power-up

2 = Cal instruction sets the zero position
Closed loop is enabled from power-up

Remarks: For activating the closed loop, the 'encmask' of the corresponding axes must be set to one. If encmask is not set or no encoder is present, the calmode only affects the axis zero position behavior.

Response: Calmode of the axes

Examples:

```
!calmode 0 0 0 Calmode behavior of axes X,Y,Z set to default operation
!calmode z 2 Set Z axis to enter closed loop instantly after power-up
?calmode Read calmode of all axes
?calmode y Read calmode of Y axis only
```

13.5. carequired (Calibration Required)

Syntax: !calrequired or ?calrequired

Parameter: x, y, z, a or none
0 or 1

Description: The calibration required mode offers a mechanism to avoid axis travel until the !cal instruction is executed. It can be set for each axis individually.

0 = Axes can move even without !cal (default)

1 = Axes are halted as long as !cal was not executed (

Response: Calrequired setting of the axes

Examples:

```
!calrequired 0 0 0 No cal required to enable X,Y,Z axis move (default)
!calrequired z 1 Cal required to enable axis move in Z
?calrequired Read calrequired mode of all axes
?calrequired y Read calrequired mode of Y axis only
```

13.6. caltimeout (Calibration Timeout)

Syntax: !caltimeout or ?caltimeout
Parameter: x, y, z, a or none
1 to 120 (seconds, as integer)

Description: This instruction specifies the timeout for calibration (cal) and range measure (rm) instructions. It can be set for each axis individually, depending on axis length and velocities. The default value is 40 or 60 seconds.

Remarks: For long axes (over 350mm) the default timeout of 40s is insufficient and must be increased, as a typical cal/rm travel velocity is 10mm/s.

Response: Calibration+RangeMeasure timeout in seconds

Examples:

```
!caltimeout 60 60 60    set the cal/rm timeout for X,Y,Z to 60 seconds
!caltimeout x 40       set the cal/rm timeout for X to 40 seconds
?caltimeout            read timeout of all axes
?caltimeout z         read timeout of Z axis only
```

13.7. caliboffset (Calibration Offset)

Syntax: !caliboffset or ?caliboffset

Parameter: x, y, z, a or none
Position (0.0 ... 100mm, depends on 'dim')

Description: This instruction specifies a calibration position offset. When executing a 'cal' instruction, the axis travels this extra distance away from the limit switch E0 and sets the origin (axis zero position) there. The unit depends on the current 'dim' settings. Valid position range is "0.0 to 100mm equivalent". The default value is 0.

Response: Calibration Cal switch position offset

Examples:

```
!caliboffset 10 5.5 0.1 set the calibration offset for X, Y and Z axis
!caliboffset x 0.05    set the calibration offset for X axis to 0.05
?caliboffset          read the calibration offset of all axes
?caliboffset y        read the calibration offset of Y axis only
```

13.8. roffset (Range Measure Position Offset)

Syntax: !roffset or ?roffset

Parameter: x, y, z, a or none
Position (0.0 ... 100mm, depends on 'dim')

Description: Similar to caliboffset, this instruction specifies an extra position offset for the 'rm' instruction. The axis travels this extra distance away from the upper limit switch EE and sets upper limit position there. The unit depends on the current 'dim' settings. Valid position range is "0.0 to 100mm equivalent". The default value is 0.

Response: Range Measure RM switch position offset

Examples:

```
!roffset 1 1 1    set the range measure offset to 1 (mm at dim 2) for X, Y and Z
!roffset z 0.1    set the range measure offset to 0.1 (mm at dim 2) for Z only
?roffset          read range measure position offset of all axes
?roffset z        read range measure position offset of Z axis only
```

13.9. caldir (Calibration Direction)

Syntax: !caldir or ?caldir

Parameter: x, y, z, a or none
0 or 1

Description: Dummy instruction, has no function. 'axisdir' may be used to change the axis direction.

Response: 0 or 1

Examples:

```
?caldir          read caldir of all axes
?caldir x        read caldir of X axis only
!caldir y 1      set Y caldir to positive direction
!caldir 0 0 1    set Z caldir to positive direction, X and Y to negative
```

13.10. calbspeed (Calibration Speed for Retraction)

Syntax: !calbspeed or ?calbspeed

Parameter: x, y, z, a or -1
0.1 to 8000 [*0.01 revolutions/s]

Description: **(Available in EXTMODE=0 only, else use calvel/rmvel)**
Set or read the cal/rm calibration speed which is used for traveling out of the limit switches E0 and EE.

Remarks: RESTRICTIONS APPLY DUE TO BACKWARDCOMPATIBILITY. See examples. Setting the calbspeed without specifying an axis will set all axes to this one value. It is recommended to access axes individually. Refer to examples below. Calbspeed is only available in **extmode=0**. For improved behavior and flexibility please refer to the **calvel**, **rmvel** instructions, which become available with **extmode=1** and replace the calbspeed and vel.

Response: Currently used calibration back speed [in 1/100 motor rev/s]

Examples:

```
!calbspeed 50 50  ILLEGAL INSTRUCTION!  
!calbspeed 15    COMPATIBILITY RESTRICTIONS! 0.15 [revolutions/s] for all axes!  
?calbspeed      COMPATIBILITY RESTRICTIONS! returns one parameter!
```

```
?calbspeed -1    read the the limit switch retraction speed of all axes  
!calbspeed z 20  set the limit switch retraction speed for Z only (recommended)  
?calbspeed x     read the limit switch retraction speed for X (recommended)
```

13.11. calrefspeed (Reference Signal Calibration Speed)

Syntax: !calrefspeed or ?calrefspeed

Parameter: x, y, z, a or -1
0.1 to 8000 [*0.01 revolution/s]

Description: Reference mark calibration speed. This speed is used when searching the encoder reference mark. The default value is 32 (0.32 rev/s). There is only one value for all axes.

Remarks: RESTRICTIONS APPLY DUE TO BACKWARDCOMPATIBILITY. See examples. **It is recommended to use the new instruction 'encrefvel'.**

Response: Currently used calrefspeed [in 1/100 motor rev/s]

Examples:

```
!calrefspeed 5 5  ILLEGAL INSTRUCTION!  
!calrefspeed 15  COMPATIBILITY RESTRICTIONS! 0.15 [revolutions/s] for all axes!  
?calrefspeed     COMPATIBILITY RESTRICTIONS! returns one parameter!
```

```
?calrefspeed -1  read the the referencing speed of all axes  
!calrefspeed z 20 set the referencing speed for Z only (recommended)  
?calrefspeed x   read the referencing speed for X (recommended)
```

13.12. encrefvel (Encoder Ref Signal Calibration Velocity)

Syntax: !encrefvel or ? encrefvel

Parameter: x, y, z, a or none
0.000001 to 3000 [rev/s] (or [mm/s] if dim=9)

Description: Replaces the !calrefspeed instruction.
Set or read the velocity, at which the reference mark search is performed (during !cal, after releasing the limit switch).

Response: Currently used encrefvel in [rev/s] or [mm/s] when dim=9

Examples:

```
!encrefvel 5 5 5 Set encoder reference mark search velocity to 5 (mm/s @ dim=9)
!encrefvel z 0.5 Set encoder reference mark search velocity for Z axis to 0.5
?encrefvel Read velocities of all axes
?encrefvel y Read velocities of Y axis only
```

13.13. refdir (Direction for Searching Reference Signal)

Syntax: !refdir or ?refdir

Parameter: x, y , z, a or none
0 or 1

Description: DUMMY INSTRUCTION.
Specifies or reads the direction in which to search the reference switch [REF]. This switch is not available with TANGO controllers.

Response: 0 = search in negative direction (default)
1 = search in positive direction

Examples:

```
!refdir y 1 set the Y-axis reference search to positive direction
!refdir 1 1 0 set the reference search direction of X, Y and Z axis
?refdir read reference search directions of all axes
?refdir x read reference search direction of X axis only
```

13.14. calpos (Calibration Position)

Syntax: !calpos or ?calpos
Parameter: x, y, z, a or none
 position value (unit depends on 'dim')

Description: Used, in combination with an encoder, to measure calibration position accuracy (repeatability of the origin). During calibration the encoder signal period, where the limit switch E0 was released and the origin (pos=0) was set, is stored. This position value within an encoder period can be read with '?calpos'. The position may also be set to another value. The unit depends on the setting of 'dim'. Valid range is 0 to 100mm equivalent.

Remarks: This instruction is used for systems with encoders only.

Response: A position within the range of one encoder signal period

Examples:
?calpos y read calibration position of Y axis (e.g. returns 0.0000)
?calpos read calibration position of all axes
!calpos 0 0 0 set calibration positions to zero (X, Y and Z)
!calpos y 0 set calibration position of Y axis to zero

13.15. calvel (Calibration Velocities for CAL Instruction)

Syntax: !calvel or ?calvel
Parameter: x, y, z, a or none
two velocities >0.0 (in [motor rev/s] or [mm/s] if dim=9)

Description: **This instruction is accessible in EXTMODE=1 only.**
If **extmode** is set to 1, this instruction replaces the **calbspeed** and **vel** parameters for the calibration (!cal) function:

Parameter 1 = speed towards cal limit switch (find)
Parameter 2 = speed out of cal limit switch (release)

The unit is [motor rev/s] for 'dim' settings 0 to 8, and [mm/s] fro dim=9.

The travel speed towards the limit switch should not be more than 10mm/s to prevent mechanical damage (axis must stop after sudden limit switch event).

The travel speed out of (releasing) the limit switch should be low for achieving high position accuracy, e.g. 0.5mm/s

Response: Two velocities (towards and out of limit switch) per axis

Examples:

```
!calvel x 10 0.5 Cal in X moves
A) towards lower limit switch with a velocity of 10 [rev/s]
   or [mm/s], depending on dim, and
B) out of the limit switch with velocity 0.5
```

```
?calvel read cal velocities of all axes (xvel1 xvel2 yvel1 yvel2 etc.)
?calvel y read cal velocities of Y axis only (e.g. returns 10.000 0.500)
```

13.16. rmvel (Range Measure Velocities for RM Instruction)

Syntax: !rmvel or ?rmvel
Parameter: x, y, z, a or none
two velocities >0.0 (in [motor rev/s] or [mm/s] if dim=9)

Description: **This instruction is accessible in EXTMODE=1 only.**
If **extmode** is set to 1, this instruction replaces the **calbspeed** and **vel** parameters for the range measure (!rm) function:

Parameter 1 = speed towards rm limit switch (find)
Parameter 2 = speed out of rm limit switch (release)

The unit is [motor rev/s] for '**dim**' settings 0 to 8, and [mm/s] fro dim=9.

The travel speed towards the limit switch should not be more than 10mm/s to prevent mechanical damage (axis must stop after sudden limit switch event).

The travel speed out of (releasing) the limit switch should be low for achieving high position accuracy, e.g. 0.5mm/s

Response: Two velocities (towards and out of endswitch) per axis

Examples:
!calvel x 10 0.5 Rm in X moves towards endswitch with velocity 10 [rev/s] or [mm/s], depending on dim and out of the endswitch with velocity 0.5
?calvel read rm velocities of all axes
?calvel y read rm velocities of Y axis only (e.g. returns 10.000 0.500)

13.17. autopitch (Measure Pitch after CAL Instruction)

Syntax: !autopitch or ?autopitch
Parameter: x, y, z, a or none
0 or 1

Description: Measures and sets the spindle pitch each time when executing a cal instruction.

Remarks: Only works if encoders are present.
Not recommended for spindles and precision drives.

Response: Autopitch enabled (1) or disabled (0, default)

Examples:
!autopitch 1 1 0 Measure and readjust pitch after each cal instruction X and Y
!autopitch y 1 Measure and readjust pitch after each cal instruction in Y
?autopitch read autopitch setting of all axes
?autopitch x read autopitch setting of X axis

Pitch measuring sequence example:
"!autopitch x 1"
"!cal x"
[wait for reply]
"!autopitch x 0"
"?pitch x"
"!save"

14. Move Instructions

Move instructions command the TANGO to move axes to certain positions or to travel at a constant, specified velocity. Positioning can be executed for individual axes or combined as a vector move.

Positioning (moa, mor, m, moc) is based on the velocity (vel) and acceleration (accel, accelfunc) settings. If executed as a vector of 2 or more axes, the TANGO automatically selects the "leading" axis and adjusts the other axes in a way that none of their velocity and acceleration parameters is exceeded.

Moa and mor are similar instructions. Moa travels based on absolute coordinates, defined by the axis origin or the overwritten "pos", while mor travels relative to the current position.

The "m" instruction can be used to achieve high vector throughput with little communication overhead (often combined with autostatus=3). The relative distances have to be preset - either the last "mor" or a "distance" instruction.

A special case of positioning is available with the **!go** instruction. It does not move as a vector, here each axis travels at its own velocity and accel settings. Also it only provides linear acceleration (accelfunc does not apply). The advantage of the **!go** instruction is that it can be overwritten at any time with no need to abort the currently executed move. It will smoothly change directions. Target applications are e.g. focusing via a slider or tracking a mouse cursor position.

The third option for axis travel is "speed move". Here not positions but velocities are specified. The addressed axes travel at this velocities until stopped, aborted or reaching a position limit. Like **!go**, the speed instruction is also not executed as a vector and does not use the accelfunc. Speed requires the "joystick" to be enabled.

Remarks on relative positioning:

Due to internal resolution a sequence of many consecutive relative moves may lead to (minor) absolute position deviation. Executing an absolute move at times is recommended.

Also, if HDI is enabled, minor changes in position may occur due to the connected device (Joystick, ERGODRIVE). Which can also accumulate position error when only using relative moves. It is recommended to deactivate the HDI when using relative moves (by instructions **joy** or **joydir**).

14.1. moa (Move Absolute)

Syntax: !moa or moa
Parameter: x, y, z, a or none
position values within \pm maxpos

Description: This instruction commands one or more axes to the specified position(s). The position unit depends on **dim** settings.

Response: Depends on **autostatus** settings, which per default is set to 1. Each commanded (and enabled) axis responses either '@' after successfully completing the move, or 'E' if an error occurred. For further information on response options, please refer to **autostatus** and **statusaxis**.

Examples:
moa 10 0 20 axes X,Y,Z travel to the specified positions (vector move)
moa 10 0.5 axes X and Y travel to the specified positions (vector move)
moa x 10.2 X-axis travels to position (e.g. 10.2mm if dim=2)
moa 10.2 same as "moa x 10.2"
moa y 34.5 Y-axis travels to position (e.g. 34.5mm if dim=2)

14.2. mor (Move Relative)

Syntax: !mor or mor
Parameter: x, y, z, a or none
distance values within \pm maxpos

Description: This instruction commands one or more axes relative to the current position. The position unit depends on **dim** settings.

Response: Depends on **autostatus** settings, which per default is set to 1. Each commanded (and enabled) axis responses either '@' after successfully completing the move, or 'E' if an error occurred. For further information on response options, please refer to **autostatus** and **statusaxis**.

Examples:
mor 10 0 -20 axes X,Y,Z travel the specified distances (vector move)
mor 10 0.5 axes X and Y travel the specified distances (vector move)
mor x 10.2 X-axis travels the specified distance (e.g. 10.2mm if dim=2)
mor 10.2 same as "mor x 10.2"
mor y -34.5 Y-axis travels e.g. (if dim=2) 34.5mm backwards

14.3. m (Move Relative Shortcut)

Syntax: !m or m
Parameter: none

Description: The instruction is a shortcut (abbreviation) of mor. It is useful to speed up communication especially for consecutive identical vectors. The vector is taken from the preceding !mor or !distance instruction. The instruction will move all enabled axes if their distance is not zero.

Response: Depends on state of autostatus, recommended is mode 3.

Example: Positioning sequence involving moa,mor,m

!moa 1 2 3 4	will move to 1 2 3 4	
!mor 1 1 1 1	will move to 2 3 4 5	(mor sets distance)
m	will move to 3 4 5 6	
!distance 0 2 0 0		(specify distance)
m	will move to 3 6 5 6	
m	will move to 3 8 5 6	

14.4. distance (Distance for m)

Syntax: !distance or ?distance
Parameter: x, y, z, a or none
Distance (within +-maxpos)

Description: This instruction sets the travel distance for !m instructions. The unit depends on the 'dim' settings.

Remarks: The distance value is also set by each '!mor' instruction. Distances must be defined for all axes, axes that shall not move have to be set to distance = 0.

Response: Currently used value for distance (unit depends on 'dim')

Examples:

?distance	read distance values of all axes
?distance z	read distance value of Z axis only
!distance 10 20 0	set X and Y distance
!distance 1 2 0.5	set X, Y and Z distance
!distance y 20.2	set Y distance only, other axes keep their distance values

14.5. moc (Move to Center)

Syntax: !moc or moc
Parameter: x, y, z, a or none

Description: The specified or all enabled axes travel to the center position between their lower and upper software limit. It is recommended to first execute the !cal and !rm instructions.

Response: Depending on 'autostatus' settings, each successful centered axis responds with "@".

Examples:

moc	all axes travel to their center position
moc y	Y-axis travels to the center position

14.6. go (Go To Position)

Syntax: !go or go
Parameter: x, y, z, a or none
 position values within \pm maxpos

Description: Used for position tracking applications.
 Similar to the '**moa**' instruction, 'go' executes a move of one or more axes to an absolute position.

The differences to absolute move instructions are:

- Go can be overwritten anytime, also when moving, by another go position (without the need to abort or stop it first)
- Go is no vector move, each axis moves at its own velocity (**vel**) and acceleration (**accel**)
- It supports only linear acceleration
- No autostatus reply on completion (polling of '**statusaxis**' \neq 'M' required)

The unit of the position values depends on **dim**.

Remarks: In order to check for a completed go move, please poll the '**statusaxis**' state, which should not be 'M' then.

In order to abort a running go instruction either '**a**' can be used, which stops at **stopaccel** or the '**!speed**' can be set to zero which will stop the move at normal **accel** acceleration.

Response: None.

Examples:
go 10.7 14 axes X and Y travel to the specified positions (no vector)
go x 10.2 the X-axis travels to position 10.2 ([mm] assume dim=2)
go 10.2 same as "go x 10.2"
go 10.1 -0.5 0 axes X, Y, Z travel to the specified positions (no vector)
!speed 0 0 0 stops the go instruction for X, Y and Z axis (using **accel**)
!speed z 0 stops the go instruction for Z axis only

Sequence example for changing velocity within a running go instruction:

```
!vel z 10  
go z 100                => starts the absolute move at a velocity of 10  
!vel z 1  
go z 100                => the still running go instruction adapts to the new velocity
```

14.7. speed (Speed Move)

Syntax:	!speed or ?speed
Parameter:	x, y, z, a or none +-100.0 [rev/s] or [mm/s] in dim=9 only
Description:	Start axes to travel at the specified velocities. Travel can be stopped by setting the speed to zero. Or when reaching a soft- or hardware limit. Speed uses the acceleration set by accel and only provides linear acceleration. The speed instruction is also called digital Joystick, so it only applies when the corresponding HDI (joystick) axis is enabled by the joydir instruction.
Remarks:	For endless rotation please refer to !zero and modulomode=1 . Setting speed to zero also stops the go instruction. Joydir enables/disables individual axes for the speed instruction.
Response:	Currently executed speed in [rev/s], or [mm/s] if dim=9 There is no autostatus reply.
Examples:	<pre>!speed 33 0.01 start speed move for X= 33[rev/s] and Y= 0.01[rev/s] !speed 10 start speed move for X-axis to 10[revolutions/s] !speed y 0.001 start speed move for Y-axis !speed 0 0 0 0 stop speed move for all axes !speed 0 stop speed move for X-axis !speed z 0 stop speed move for Z-axis ?speed read the currently executed speed of all axes ?speed z read the currently executed speed of Z-axis only</pre>

14.8. a (Abort the Current Move)

Syntax:	!a or a or [hex 0x03]
Parameter:	x, y, z, a or none
Description:	This instruction stops either all axes or the specified axis and sets them into position reached state. Stop is performed with high acceleration (set by stopaccel). Most TANGO controllers also provide the "Ctrl+C" (hex 0x03) special character stop, which stops all axes and also bypasses the parser (faster response and independent of blocking instructions).
Remarks:	Abort might fail in special cases of closed loop errors. In such case closed loop has to be deactivated as well.
Response:	Depends on the instruction being executed (moa, speed, go etc.) and autostatus . If a move was aborted in autostatus=1 (default) and all axes stopped, each axis responds an ,@'.
Example:	<pre>a (abort move of all axes) a y (abort move of Y axis only)</pre>

14.9. delay (Set the Delay Time for Consecutive Moves)

Syntax: ?delay or !delay

Parameter: 0 to 10000 [ms]

Description: This instruction will insert a delay time before executing a move (delayed start). There is only one value for all axes.
Applies to: moa,mor,moc,m

Response: Delay time in [ms]

Examples:

!delay 500 Delay the start of a move instruction by 0.5 seconds

?delay Read the delay time

14.10. pause (Set the Pause after Position Reached)

Syntax: ?pause or !pause

Parameter: 0 to 10000 [ms]

Description: Complementary to "delay", this instruction adds a pause time after the axes have reached their target positions. In autostatus=1 mode the "@@@" response is delayed by this time. It may be used to insert an automatic settling time after moa,mor,moc or m. There is only one value for all axes.

Response: Pause time in [ms]

Examples:

!pause 10 Delay the autostatus response of a move by 10 milliseconds

?pause Read the pause time

14.11. pos (Read or Set Position)

Syntax: !pos or ?pos
Parameter: x, y, z, a or none
 Position (within +-maxpos)

Description: This instruction either reads or sets the axis position.
 If set, this defines a new absolute position of the axis.
 The unit depends on the selected dimension (**dim**).

Remarks: For axes with encoders, the encoder position can be returned
 by setting its '**encpos**' to 1.

 The effect of manipulating positions with '!pos' can be
 removed by the instruction '**posclr**'. Also the difference
 (offset) from the original zero position can be read by it.

Response: Axis position(s) (depends on **dim**, also **enc** and **encpos** state)

Examples: ?pos Read all axis positions
 ?pos z Read Z axis position only
 !pos 100 200 Set the current X and Y axis positions
 !pos -0.1 Set the current X position to -0.1 (unit depends on dim)
 !pos y 2000 Set the current Y position to be 2000 (unit depends on dim)

14.12. posclr (Clear Position Offset)

Syntax: !posclr or ?posclr
Parameter: x, y, z, a or none

Description: Reset or read the position offset to the axis origin, which
 was added by a !pos instruction.

 The absolute position can be redefined by "!pos". In order to
 return to the original absolute position, clearpos offers
 reading or clearing of the changes made by !pos.

Response: Position offsets (depending on **dim**)

Examples: !posclr x (reset X to original position)
 !posclr (reset all positions to original position)
 ?posclr (read position offset of all axes)

 ?pos => 1.0000 **2.0000** 3.0000
 !pos y 8 *(here a position offset of 8-2=6 is added to Y)*
 ?pos => 1.0000 **8.0000** 3.0000
 ?posclr => 0.0000 **6.0000** 0.0000
 !posclr *(here the !pos set position offsets are removed)*
 ?pos => 1.0000 **2.0000** 0.0000

14.13. zero (Set Internal Position to Zero)

Syntax: !zero or zero
Parameter: x, y, z, a or none

Description: Unlike "!pos 0", the "!zero" instruction also resets the internal position counter to zero. It has to be used in applications where axes exceed the position limits, e.g. filter wheels (in such case a "!pos 0" instruction is not sufficient). The zero instruction should be executed after completing one or several complete revolutions, before reaching the software limits. So the reference point remains at the same position.

Response: none.

Examples:
!zero Set all internal positions to zero
!zero z Set Z axis position to zero

14.14. clearpos (Set Internal Position to Zero)

Syntax: !clearpos or clearpos
Parameter: x, y, z, a or none

Description: For compatibility with LStep controllers. Functionality is almost the same as with the 'zero' instruction. The only difference is that the clearpos instruction is not executed when in closed loop.

Response: none.

Examples:
!clearpos Set all internal positions to zero
!clearpos x Set X axis position to zero

15. HDI Instructions (Joystick, Trackball, ERGODRIVE)

The HDI (human device interface) provides manual control of the axes and also supports special functions.

The HDI interface accepts hot plugging of the devices. It is possible to unplug, plug or change the input devices during operation of the controller.

The HDI velocities are limited by the **secvel** velocity as long as no **cal** and **rm** sequence has been executed. The axis travel will stop at either the hardware limit switches or the software limits (defined by **lim** instruction).

The Joystick velocities are either taken from the current axis velocity **vel** or, if **'extmode'** is enabled as an independent **joyvel**.

The **keymode** functionality enables selection of different **keyspeed** or **zwtravel** wheel velocities by pressing the function keys of the joystick. Please refer to **keymode** for further informations.

The optional **multi-function wheel**, found on several HDI devices, can be assigned to any axis (instruction **zwaxis**) and the LED100 brightness via **hdimode**.

15.1. joy (Generally Enable/Disable HDI)

Syntax: !joy or ?joy
Parameter: 0, 1, 2, 3, 4 or 5

Description: Generally enable or disable the connected HDI device (joystick, trackball, ERGODRIVE etc.)
It is recommended to only use the values 0 or 2. For compatibility, a value of 1 has the same effect as 2.

0 = OFF : disable HDI device
2 = ON : enable HDI device (default setting)

If joy is switched from an ON state to OFF (0), an automatic status message like "@@@" is generated. If this is not wanted a workaround is using **'joydir'** to disable the HDI or temporarily disabling autostatus.

Remarks: It also enables or disables the **'speed'** instruction.

Response: HDI enable state

Examples:

```
!joy 0                disable the HDI device (e.g. joystick) and speed instruction
!joy 2                enable  the HDI device (default) and speed instruction
?joy                   read HDI enable state
```

Behavior examples / sequences:

```
-----
?joy     ==> 2        (HDI is enabled)
!joy 0   ==> @@@-.   (response when switched to disable, default autostatus on)
!joy 0               (no response when joy already is disabled)
!joy 2               (no response when joy is enabled)
-----
!autostatus 0        (workaround #1 to avoid response when disabling)
!joy 0
!autostatus 1
-----
!joydir 0 0 0 0      (workaround #2 is to use 'joydir' instead)
!joydir 2 2 2 2      (make sure the direction is correct, 2 or -2)
-----
```

15.2. joydir (Joystick Direction or Assign Joystick per axis)

Syntax: !joydir or ?joydir
Parameter: x, y, z, a or none
 and 0, 1, 2, -1, -2

Description: In addition to the '**joy**' instruction, joydir can be used to enable/disable individual HDI axes and set their directions. It is recommended to use the values 2, 0 or -2 only. The options are:

0 = Disable HDI axis (e.g. joystick deflection is ignored)
1 = Enable HDI axis, no motor current reduction
2 = Enable HDI axis, current reduction supported (default)
-1 = Same as 1, direction reversed
-2 = Same as 2, direction reversed

Remarks: Please also make sure that the joystick function is globally enabled by the '**joy**' instruction.

When using a 4 axis controller with a 3 axis HDI device, the 3rd axis must be assigned to axis 3(=default setting), 4 or both (3 and 4) by enabling/disabling their joydir!

This instruction also enables or disables the '**speed**' move for individual axes, but does not change the speed directions.

Response: HDI directions of the axes or specified axis

Examples:
!joydir -2 enable HDI X-axis in reversed direction
!joydir z 0 disable HDI Z-axis
!joydir 2 2 0 2 set positive direction, allow current reduction, assign the joysticks 3rd axis to the controller A axis instead of Z
?joydir read HDI enable/direction setting of all axes
?joydir y read HDI enable/direction setting of Y axis only

15.3. joychangeaxis (Change Joystick X and Y Axis)

Syntax: !joychangeaxis or ?joychangeaxis
Parameter: 0 or 1

Description: Change the assignment of the Joystick X and Y axes.

0 = no change (default)
1 = Joystick X and Y axes changed (X=Y, Y=X)

Remarks: Only for Joystick devices.

Response: Joystick X-Y change setting

Examples:
!joychangeaxis 1 change X and Y axis of the Joystick
?joychangeaxis read Joystick X,Y change state



15.4. joywindow (Joystick Window)

Syntax: !joywindow or ?joywindow
Parameter: 0 to 100

Description: This instruction sets the center position threshold of the Joystick in digits. A deflection, as long as it is in this window, has no effect. There is only one value for all axes. The default value of +/- 14 should not be reduced, as this may result in slow unwanted creeping of axes even when the joystick is apparently not deflected. Increasing the value will reduce the velocity resolution (available steps).

Response: joywindow [in digits]

Examples:
?joywindow read joystick window
!joywindow 14 set joystick window to +-14

15.5. joyvel (Joystick Velocity)

Syntax: !joyvel or ?joyvel
Parameter: x, y, z, a or none
0.000001 to 200 [revolutions/s] or equiv. [mm/s] if dim=9

Description: **This instruction is accessible in extmode 1 only!**
In extmode=1 this instruction must be used to set the joystick velocities. As the vel instruction then has no influence to the joystick velocity. In normal mode (extmode=0) the joystick velocities are derived from the axis vel settings.

Response: Currently used joystick velocities

Examples:
!joyvel 12.5 20 0.4 Set joystick velocities for 3 axes
!joyspeed z 1 Set joystick velocities for z to 1 [rev/s], (e.g. dim=2)
or [mm/s] if dim=9
?joyvel x Read joystick velocity of X-axis

15.6. joyspeed (Joystick Speed Presets for BPZ Device)

Syntax: !joyspeed or ?joyspeed
Parameter: 1, 2 or 3 and
0.000001 to 200 [revolutions/s]

Description: **Only used by a customer designed HDI device** (called BPZ), this instruction sets the joystick speeds for the three speed buttons (Slow, Medium, Fast). Unit is in motor revolutions per second (like 'vel' instruction). While the velocity applies to all axes, each speed button has to be set individually:
1 = Slow Button speed, one parameter for all axes
2 = Medium Button speed, one parameter for all axes
3 = Fast Button speed, one parameter for all axes

Response: Speed currently assigned to the specified button in [rev/s]

Examples:
?joyspeed 1 Read "Slow" joystick button speed
!joyspeed 3 30 Set "fast" joystick button speed to 30 [revolutions/s]

15.7. keymode (Joystick Key Mode)

Syntax: !keymode or ?keymode

Parameter: 0, 1 or 2

Description: Assign keyspeed values to the Joystick buttons. The Joystick can be used with two different velocity settings defined by the keyspeed instruction. The default keyspeed 1 is set to 1mm/s (slow) and keyspeed 2 to 10mm/s (fast). In keymodes 1,2 'vel' or 'joyvel' instructions have no effect. In such case refer to '**keyspeed**', which will be used then. Please note that other special functions which require Joystick buttons (e.g. **snapshot modes**) should not be used at the same time as keymode.

A) If Joystick toggle mode ('**hdimode**') is selected:

--> F1 toggles XY between the keyspeed values 1 and 2
--> F4 toggles Z keyspeeds (available from firmware 1.56)

B) If '**hdimode**' is not set to toggle mode, the behavior is:

Pressing F1 selects keyspeed2 values of X and Y axis,
while F4 selects keyspeed1 values of X and Y axis.

Pressing F2 selects keyspeed2 value of the Z axis,
while F3 selects keyspeed1 value of the Z axis.

In case of joysticks with the optional multi-function wheel, the wheel velocities can be selected by pressing F1, F4, or no key. Please refer to the '**zwtravel**' description.

Recommended Joystick settings are:

2&3 axis Joystick: hdimode 0 or 1 to either toggle velocities by pressing F2/F3, F1/F4 (0) or to toggle by pressing F1 (1).

Joystick with wheel: hdimode 0 to toggle XY by F2,F3 and the wheel by pressing none/F1/F2.

Parameter description:

0 = Normal key functions
1 = X/Y and Z Joystick velocity, preset **keyspeed** 1 [F4,F3]
2 = X/Y and Z Joystick velocity, preset **keyspeed** 2 [F2,F1]

Response: keymode as decimal number

Examples:

!keymode 1 slow preset keymode
?keymode => 0 (in case keymode is disabled)

15.8. keyspeed (Joystick Key Speed Presets)

Syntax: !keyspeed or ?keyspeed
Parameter: x, y, z, a or none
 0.000001 to 3000 [mm/s]

Description: Two Joystick velocities can be set for each axis individually. The first parameter is called the slow value and the second parameter is fast. Unit is always mm/s, independent from **dim**.

Remarks: In keymode 1 or 2 the X and Y values (slow/fast) are assigned to F4 and F1, while the Z values are assigned to F3/F2. Please also refer to **keymode**. Toggle mode can be used as well. Please refer to **hdimode** (bit 1) for further information

Response: Two floating point values per axis (slow fast)
 single axis : => [keyspeed1/slow] [keyspeed 2/fast]
 multiple axes: => [slow_x] [fast_x] [slow_y] [fast_y] ...

Examples:
?keyspeed x => 1.00 10.00 (Read X Joystick button velocity)
?keyspeed => 1.00 10.00 1.00 10.00 0.10 1.00 (Reply of 3 ax. controller)
!keyspeed z 0.1 1 (Set Joystick keyspeed1 to 0.1 and keyspeed2 to 1 [mm/s])
!keyspeed 5 20 2 10 0.2 2 (Set 3 axes at once)

15.9. joycurve (Joystick Characteristic)

Syntax: !joycurve or ?joycurve
Parameter: x, y, z, a or none
 0, 1, 2

Description: The speed characteristic of Joystick deflection can be defined for each axis individually.

 0 = Logarithmic (default)
 1 = Linear
 2 = Quadratic

Response: Currently used characteristic

Examples: !joycurve 0 0 0 => set X,Y,Z axes to logarithmic
 !joycurve z 1 => set Z axis to linear
 ?joycurve => read characteristic of all axes

15.10. key (Read HDI Device Key State)

Syntax: ?key or key

Parameter: none or key number 1, 2, 3, 4

Description: This instruction reads the state of all 4 or the specified HDI device key(s).

0 = key is currently released or not available

1 = key is currently pressed

Response: 1 or 4 Key states, each either 0 or 1

Examples: key => query all keys, returns 4 numbers, e.g. 0 0 0 0

key 1 => query only key 1 (e.g. F1 Joystick button)

key 3 => query only key 3 (e.g. F3 Joystick button)

15.11. keyl (Read HDI Device Latched Key State)

Syntax: keyl, ?keyl or !keyl

Parameter: none or key number 1, 2, 3, 4

Description: The ?keyl or keyl instruction reads the latched state of the specified or all 4 HDI device keys. The latched state of the requested key(s) is cleared after reading.

The instruction !keyl clears the latched state of the specified or all keys to zero (0) without reading.

0 = key is/was released since last keyl or ?keyl instruction

1 = key is/was pressed since last keyl or ?keyl instruction

Response: 1 or 4 Latched key states, each either 0 or 1

Examples: keyl => read+clear all 4 keys, returns e.g. 0 1 0 0

keyl 1 => read+clear only key 1 (e.g. F1 Joystick button)

?keyl 1 => same as "keyl 1"

!keyl 2 => clear latch state of key 2 only (to zero)

!keyl => clear latch state of all 4 keys (to zero)

15.12. hwfactor (Coaxial-/ERGODRIVE Transmission Factor)

Syntax: !hwfactor or ?hwfactor

Parameter: x, y, z, a or none
and -200.0 to 200.0

Description: Aaxis travel distance in millimeter per coaxial drive revolution. Negative factors reverse the travel direction. (The hardware provides about 100000 steps per revolution.)

Remarks: Some HDIs provide a switch to change between two different factors. Please refer to '**hwfactorb**'.

Response: Currently used factor(s)
As floating point number(s) between -200.0 and +200.0

Examples:

```
!hwfactor 14 14 => One knob revolution in X or Y results in 14mm axis travel
!hwfactor x 100 => One knob revolution in X results in 100mm travel
?hwfactor       => Read transmission factor of all axes
```

15.13. hwfactorb (Alternate Coaxial-/ERGODRIVE Factor)

Syntax: !hwfactorb or ?hwfactorb

Parameter: x, y, z, a or none
and -200.0 to 200.0

Description: Alternate (second) parameter for travel distance per coaxial drive revolution '**hwfactor**'. Available with e.g. ERGODRIVE and Pilot stage. Negative factors reverse the travel direction.

Response: Currently used alternate coaxial drive factor(s)
As floating point number(s) between -200.0 and +200.0

Examples:

```
!hwfactorb 26.6 26.6 => One knob revolution in X or Y results in 26.6mm travel
?hwfactorb y        => Read alternate transmission factor of Y axis only
```

15.14. hwfilter (Coaxial-/ERGODRIVE Noise Filter)

Syntax: !hwfilter or ?hwfilter

Parameter: 0 or 1

Description: Coaxial drive noise filter.

1 = Noise filter is active (recommended, default)
0 = Noise filter is deactivated (finer step resolution)**

The filter is activated/deactivated for X and Y axes at once.
** Disabling the filter can result in a finer resolution, but it also causes position inaccuracy e.g. between automatic moves or when the axis is not moving: Its signal noise will cause a permanent slight position jitter.

Response: State of the coaxial drive noise filter

Examples:

```
!hwfilter 0 => Disable noise filter
?hwfilter   => Read hwfilter state
```

15.15. **tbfactor (Trackball Factor)**

Syntax: `!tbfactor` or `?tbfactor`

Parameter: `x, y, z, a` or none
and `-200.0` to `200.0`

Description: Set or read the trackball sensitivity (transmission factor), which is a floating point number between `-200.0` and `+200.0`. A negative value can be used to change direction (similar to `'joydir'`). The default factor is `1`.

Response: Currently used trackball factor(s)

Examples:

```
!tbfactor x 100 => X axis is 100 times more sensitive than the default setting  
!tbfactor y 12.5 => X axis is 12.5 times more sensitive than the default  
!tbfactor 0.5 0.5 => X and Y axis set to half the default sensitivity  
?tbfactor => Read sensitivity factor of all axes
```

15.16. zwheel (Is Multi-function Wheel Available)

Syntax: ?zwheel or zwheel
Parameter: none

Description: Identify if the connected HDI device provides a Wheel.

0 = HDI device has no multi-function wheel
1 = HDI device has a multi-function wheel

Remarks: To identify the HDI device, use '**hdi**' instruction

Response: 0 or 1

Example: ?zwheel => 0

15.17. zwtravel (Multi-function Wheel Travel per Revolution)

Syntax: !zwtravel or ?zwtravel
Parameter: 1, 2 or 3 and
-50.0 to 50.0 [mm/revolution]

Description: Set or read the travel distances for one revolution of the multi-function wheel, available with several HDI devices, e.g. ERGODRIVE and Joystick.

1 = Default (used when no HDI function key is pressed)
2 = Used while Joystick F4 button is pressed (preset to slow)
3 = Used while Joystick F1 button is pressed (preset to fast)

Presets for travel distance are
1: 0.1 mm/rev (default factor)
2: 0.01 mm/rev (alternate factor, factory preset to slow)
3: 1.0 mm/rev (alternate factor, factory preset to fast)

Remarks: ERGODRIVE and Pilot stage only offer switching between two travel distances. In this case distance parameter 1 remains the default, parameter 3 is used as alternate second factor.

'**secvel**' and '**vel**' (or '**joyvel**' in **extmode** 1) may prevent faster traveling when turning the wheel.

For safety reasons, the default travel can be set to zero (0). So the axis will move only when a key is pressed (F1, F4).

It is possible to set negative values and by this offering direction change via HDI key.

The multi-function wheel can also be assigned to other axes with the '**zaxis**' instruction. By default it is set to Z.

Response: Travel distance(s) of the multi-function wheel

Examples:
?zwtravel Read all 3 travel distances: [1:default] [2:slow] [3:fast]
?zwtravel 1 Read "default" travel distance
?zwtravel 2 Read "slow" travel distance
!zwtravel 3 2.5 Set "fast" travel distance to 2.5 [mm/revolution]
!zwtravel 1 0 Set "default" parameter to zero (inactive without keypress)



15.18. zwaxis (Multi-function Wheel Axis)

Syntax: !zwaxis or ?zwaxis

Parameter: x, y, z or a

Description: Assign multi-function wheel to an axis (default: z)

Response: x, y, z or a

Example: !zwaxis a (assign wheel to axis 4)
!zwaxis x (assign wheel to axis 1)
?zwaxis => z (wheel is currently assigned to axis 3)

15.19. zwfactor (Multi-function Wheel Factor)

Syntax: !zwfactor or ?zwfactor

Parameter: 0, 1, 2 ... to 20

Description: For custom designed applications only.
Increase Wheel transmission multiplier, default=1.

0 = Wheel has no effect
1 = Wheel default (1:1)
.
.
.
20 = Wheel travels 20 times more distance

Remarks: Useful in custom designs where the application requires a different rotary encoder to provide the wheel functionality. If the chosen encoder type provides less resolution than the Joystick multi-function wheel, zwfactor can be used to adapt the behavior (here: to achieve correct **zwtravel** distances). The multi-function wheel has a resolution of 480 counts/rev. In example if the encoder has 128 counts/rev, zwfactor can be set to 4.

Response: Multiplier

Example: !zwfactor 1 (set default multiplier, as for TANGO HDIs)
!zwfactor 5 (set multiplier for lower res. Encoder wheel)
?zwfactor (Read the currently used multiplier)

15.20. tvrjoy (Pulse and Direction Joystick Functionality)

Syntax: !tvrjoy or ?tvrjoy

Parameter: 0, z, a

Description: Enables and assigns the AUX-IO pulse&direction inputs TAKT_IN, V/R_IN to an axis, providing a pulse and direction interface. The behavior is similar to the trackball, which is available as HDI device.

Remarks: The function does not provide absolute positioning accuracy. It can be compared to a HDI device behavior.

0 = Disabled (default)

z = Assigned to Z-axis

a = Assigned to A-axis

Response: Currently assigned axis

Examples:

!tvrjoy 0 Disable AUX-IO tvr joystick function

!tvrjoy z Assign AUX-IO tvr joystick function to Z-axis

?tvrjoy Query assigned axis

15.21. tvrjoyf (Pulse and Direction Joystick Factor)

Syntax: !tvrjoyf or ?tvrjoyf

Parameter: -200.0 to +200.0

Description: Set or read the AUX-IO tvrjoy transmission factor as floating point number between -200.0 and +200.0. A sign change can be used to change direction. The default setting is 1.

Response: Currently used tvr factor

Examples:

!tvrjoyf 10 Axis is 10 times more sensitive than the default setting

?tvrjoyf Read tvrjoy transmission factor

15.22. hdi (Read HDI ID)

Syntax: ?hdi or hdi
Parameter: none

Description: This instruction reads the ID number of the connected hdi device.
The second value shows how good the hardware ID code matches the theoretical ID value [in %]. This value should be more than 30 for secure device identification.

ID range = 0,1,2, ... 16 (=no device connected)
ID match = 0 (poor) ... 100 (good)

ID	DEVICE
0	(Reserved for special devices)
1	Coaxial drive
2	Custom designed console
3	ERGODRIVE
4	SmartMove
10	2x 2-Axis Joystick or 4-Axis jogbox
11	Trackball with 2-Axis Joystick
12	Joystick 2-Axis
13	Trackball with 3-Axis Joystick
14	Trackball
15	Joystick 3-Axes
16	No device connected
17	(Device identification in progress)
18	(Device initialization in progress)

Remarks: The instruction may be used to identify the connected HDI device. Additionally **'zwheel'** can be used to identify if the device also provides a multi-function wheel.

Response: HDI ID number and the hardware coded ID match in percent.

Example: ?hdi => 12 97 (hdi device nr. 12, 97% match)



15.23. hdimode (HDI Mode Options)

Syntax: ?hdimode or !hdimode

Parameter: Set LSB or more bits at once: string of 0s and 1s,
or single bit with two numbers: 0 to 15 and 0 or 1

Description: This instruction provides access to extended HDI device options.

Options may either be set by a string of bits (0s and 1s) or by specifying bit number and logic state (on/off = 1/0). The string is LSB first (bit 0 is the first and leftmost). Setting the corresponding bit to 1 enables the functionality, 0 disables it.

<u>Bit</u>	<u>Function</u>
------------	-----------------

0:	Toggle Mode for ERGODRIVE (0=off, 1=on)
1:	Toggle Mode for Joystick (in KeyMode 1 or 2) 0=select KeySpeed velocity XY with F1+F4, Z with F2+F3 1=toggle KeySpeed velocity XY by just pressing F1 from firmware 1.56 button F4 toggles Z
2:	LED100 brightness control via Joystick or ERGODRIVE (1=enabled)
3:	- reserved -
4:	- reserved -
5:	- reserved -
6:	- reserved -
7:	- reserved -
8:	- reserved -
9:	- reserved -
10:	- reserved -
11:	- reserved -
12:	- reserved -
13:	- reserved -
14:	- reserved -
15:	- reserved -

Response: Single mode bit or all 16 mode bits as ASCII string

Examples:

```
!hdimode 100010 Set mode bits 0 and 4 to "on", bits 1,2,3,5 to "off". Bits
6...15 are left unchanged.
!hdimode 0 1 Set mode bit 0 to 1 (on) = ERGODRIVE Toggle Mode selected
!hdimode 2 1 Set mode bit 2 to 1 (on)
!hdimode 3 0 Set mode bit 3 to 0 (off)
!hdimode 1111 Set mode bits 0,1,2,3 to 1 (on)
?hdimode Read the current state of all mode bits (returns 16 digits)
?hdimode 0 Read the current state of mode bit 0 (ERGODRIVE toggle mode)
```

15.24. configaxsel (Joystick Axis Select Option)

1 Syntax: !configaxsel or ?configaxsel
Parameter: 0 or 1

Description: Used in TANGO 4 axes systems.
Enable the axis select functionality when the joystick Z-axis should drive both, the controller Z and A axes.
If the A axis joystick is enabled (by joydir a/see remarks), the Z knob of the joystick either drives Z (F4 key released) or A (F4 key pressed).

1 = axis select enabled (pressing F4 key → A-axis used)
0 = axis select disabled (default: joystick Z always Z-axis)

Remarks: Please make sure that the joystick function for A axis is enabled (**'joydir a'** instruction)

Response: Axis select configuration

Examples:

!configaxsel 1 Axis select enabled (Z<->A with 3 axes joystick)
!configaxsel 0 Axis select disabled (default)
?configaxsel Read the axis select configuration (returns 0 or 1)

16. Joystick Function Key Assignments

The Joystick provides 4 function keys, F1-F4. The key states can be read by the **key** and **key1** instructions. Several operating modes of the TANGO controller also assign special functions to the F-keys. The chart shows the key assignments for the different modes:

Mode / Key		F1	F2	F3	F4
SnapShot Mode	0	-	set new point	-	-
	1	-	next point	-	-
	2	previous point	next point	prehome & first point	prehome & home
	3	-	start dissection	-	-
	7	Move sequence prehome & home	autoinc from 1st point	pause/continue	pause & previous point
Axis Select Mode		-	-	-	Joystick Z-Axis controls A-Axis ¹⁾
KeyMode		Select X,Y KeySpeed2	Select Z KeySpeed2	Select Z KeySpeed1	Select X,Y KeySpeed1
KeyMode+Toggle		Toggle X,Y KeySpeed	Toggle Z KeySpeed	-	-
Joystick has wheel		zwtravel3 (fast) ₁₎	-	Wheel "Joystick" ¹⁾	zwtravel2 (slow) ₁₎
LED Mode no wheel		-	-	Y-axis controls LED brightness ¹⁾	-
				F3+F4: Store LED brightness	
LED Mode w. wheel		zwtravel3 (fast) ₁₎	Wheel controls LED brightness ¹⁾	Wheel "Joystick" ¹⁾	zwtravel2 (slow) ₁₎
				F3+F4: Store LED brightness	

1) Function selected only as long as key pressed.

In all other cases the function is selected or executed by pressing the key.

When selecting more than one mode at once, function keys may become assigned to several functions at once.

17. Digital and Analogue I/O

TANGO Desktop and TANGO PCI/PCI-S/PCI-E controllers provide several I/O options which become available with the optional auxiliary I/O port:

Digital I/O, two analogue outputs (channel 0 and 1) and one analogue input. (Furthermore the HDI Interface analogue inputs can be read via `'anain'`, which offers additional analog 0-5V inputs if no HDI device is connected.)

TANGO PCI-E based controllers with optional I/O1 or Multi I/O port module provide additional 24 or 12 digital inputs and 8 digital outputs via `digin`, `digout` etc. The presence of these modules can be checked by the `det` instruction.

17.1. digin (I/O1 Digital Inputs)

Syntax: ?digin or digin
Parameter: none or 0 to 23

Remarks: Only available with TANGO PCI-E/DT-E extension module I/O1.

Description: This instruction reads the logic state of one or all digital inputs of the optional digital I/O1 extension. If called without parameter, all inputs are returned as a string of 24 characters. If called with parameter (input number), only the state of the specified input is returned.

Response: logic state of digital input(s)
 ASCII string 0 or 1, LSB (IN0) is the first/leftmost character
 0 = low, 1 = high (depends on the polarity setting `diginpol`)

Examples:
?digin read all 24 digital inputs (e.g. 000000000000000000000000)
?digin 8 read logic level of input 8 (response e.g. 1)

17.2. digout (I/O1 Digital Outputs)

Syntax: !digout or ?digout
Parameter: string of up to 8 characters 0 and 1,
 or single bit with two numbers 0 to 7 and 0 or 1

Remarks: Only available with TANGO PCI-E/DT-E extension module I/O1.

Description: This instruction sets or reads back the logic level of one or all digital outputs of the optional digital I/O1 extension. Outputs may be set either by a string of levels (up to eight 0s and 1s) or by output number and signal level. The string is LSB first (output 0 is the leftmost).

Response: current output state(s)

Examples:
!digout 11110000 The digital outputs 0,1,2,3 are set to logic ,1' and the outputs 4,5,6,7 are set to logic ,0'.
!digout 100 The digital output 0 is set to logic ,1' and the outputs 1 and 2 are set to logic ,0'. Outputs 3 to 7 are left unchanged.
!digout 5 1 set digital output 5 to logic 1 (high)
!digout 7 0 set output 7 to 0 (low)
?digout read the state of all outputs
?digout 5 read the state of output 5

17.3. diginpol (I/O1 Digital Input Polarity)

Syntax: !diginpol or ?diginpol
Parameter: string of up to 24 characters 0 and 1,
or single bit with two numbers 0 to 23 and 0 or 1

Remarks: Only available with TANGO PCI-E/DT-E extension module I/O1.

Description: This instruction sets or reads back if the I/O1 input signal inverters are activated or not. Each of the 24 inputs can be inverted individually.
The inverter may be set either by a string of levels (up to 24 0s and 1s) or by specifying the input number and inverter state. The string is LSB first (input 0 is the leftmost).

Response: current inverter setting(s)

Examples:
!diginpol 010000000000000000000000 Set all inverter states (IN1 to inverted)
!diginpol 11000 The digital inputs IN0 and IN1 are set inverted, IN2, 3 and 4 are set to non inverted, input IN5 to IN23 settings are left unchanged
!diginpol 5 1 activate inverter of digital input IN5 only
!diginpol 17 0 disable inverter of digital input IN17 only
?diginpol read the inverter setting of all 24 inputs
?diginpol 5 read the inverter setting of input 5 only

17.4. digintyp (I/O1 Digital Input Type)

Syntax: !digintyp or ?digintyp
Parameter: string of up to 6 characters 0 and 1,
or single bit with two numbers: Block 0 to 5 and level 0 or 1

Remarks: Only available with TANGO PCI-E/DT-E extension module I/O1.

Description: This instruction sets or reads back if the I/O1 pull-up / pull-down resistor settings for the 24 inputs.
The resistors are arranged in 6 blocks. Therefore inputs can only be accessed blocks of 4: IN0-3, IN4-7, ... IN20-IN23

0 = pull down
1 = pull up

The pull up/down may be set either by a string of levels (up to 6 0s and 1s) or by specifying the block number and level. The string is LSB first (block 0 is the leftmost).

Response: current pull up/down setting(s)

Examples:
!digintyp 110000 Set all pull up/downs (IN0-IN7 to pull up, rest to pull down)
!digintyp 001 Set pull up/down of IN0-IN7 to pull down, IN8-IN11 to pull up the settings for IN12 to IN23 are left unchanged
!digintyp 4 1 set block 4 (IN16-IN19) to pull up
!digintyp 2 0 set block 2 (IN8-IN11) to pull down
?diginpol read the pull up/down setting of all 6 blocks
?diginpol 5 read the pull up/down setting of input 5 only

17.5. digoutpreset (I/O1 Digital Output Presets)

Syntax: !digoutpreset or ?digoutpreset
Parameter: string of up to 8 characters 0 and 1,
 or single bit with two numbers: Output 0 to 7 and level 0 or 1

Remarks: Only available with TANGO PCI-E/DT-E extension module I/O1.

Description: This instruction sets or reads back the logic levels of one or all digital outputs of the optional digital I/O1 extension, which are applied after power up of the TANGO. Output preset levels may be set either by a string of levels (up to eight 0s and 1s) or by output number and signal level. The string is LSB first (output 0 is the leftmost).

Response: output preset value(s)

Examples:

```
!digoutpreset 11110000  After power on, the digital outputs 0,1,2,3 are set to
                        logic ,1' and the outputs 4,5,6,7 are set to logic ,0'
!digoutpreset 100      After power on, the digital output 0 is set to logic ,1' and
                        the outputs 1 and 2 are set to logic ,0'. Outputs 3 to 7 are
                        left unchanged.
!digoutpreset 5 1      set preset value of output 5 to logic 1 (high)
!digoutpreset 7 0      set preset value of output 7 to 0 (low)
?digoutpreset          read the state of all outputs
?digoutpreset 5        read the state of output 5
```

17.6. edigin (Multi I/O Digital Inputs)

Syntax: ?edigin or edigin
Parameter: none or 0 to 11

Remarks: Only available with the Multi I/O port of TANGO PCI-E/DT-E.

Description: This instruction reads the logic state of one or all digital inputs of the optional Multi I/O digital extension port. If called without parameter, all inputs are returned as a string of 12 characters. If called with parameter (input number), only the state of the specified input is returned.

Response: logic state of digital input(s)
 ASCII string 0 or 1, LSB (IN0) is the first/leftmost character
 0 = low, 1 = high (depends on the polarity setting **ediginpol**)

Examples:
?edigin read all 12 digital inputs (e.g. 000000000000)
?edigin 8 read logic level of input 8 (response e.g. 1)

17.7. edigout (Multi I/O Digital Outputs)

Syntax: !edigout or ?edigout
Parameter: string of up to 8 characters 0 and 1,
 or single bit with two numbers 0 to 7 and 0 or 1

Remarks: Only available with the Multi I/O port of TANGO PCI-E/DT-E.

Description: This instruction sets or reads back the logic level of one or all digital outputs of the optional Multi I/O extension port. Outputs may be set either by a string of levels (up to eight 0s and 1s) or by output number and signal level. The string is LSB first (output 0 is the leftmost).

Response: current output state(s)

Examples:
!edigout 11110000 The digital outputs 0,1,2,3 are set to logic ,1' and the
 outputs 4,5,6,7 are set to logic ,0'.
!edigout 100 The digital output 0 is set to logic ,1' and the outputs 1 and
 2 are set to logic ,0'. Outputs 3 to 7 are left unchanged.
!edigout 5 1 set digital output 5 to logic 1 (high)
!edigout 7 0 set output 7 to 0 (low)
?edigout read the state of all outputs
?edigout 5 read the state of output 5

17.8. ediginpol (Multi I/O Digital Input Polarity)

Syntax: !ediginpol or ?ediginpol
Parameter: string of up to 12 characters 0 and 1,
or single bit with two numbers 0 to 11 and 0 or 1

Remarks: Only available with the Multi I/O port of TANGO PCI-E/DT-E.

Description: This instruction sets or reads back if the Multi I/O input signal inverters are activated or not. Each of the 12 inputs can be inverted individually. The inverter may be set either by a string of levels (up to 12 0s and 1s) or by specifying the input number and inverter state. The string is LSB first (input 0 is the leftmost).

Response: current inverter setting(s)

Examples:

```
!diginpol 010000000000 Set all inverter states (IN1 to inverted)
!diginpol 11000 The digital inputs IN0 and IN1 are set inverted, IN2, 3 and 4
are set to non inverted, input IN5 to IN11 settings are left
unchanged
!diginpol 5 1 activate inverter of digital input IN5 only
!diginpol 7 0 disable inverter of digital input IN7 only
?diginpol read the inverter setting of all 12 inputs
?diginpol 5 read the inverter setting of input 5 only
```

17.9. edigintyp (Multi I/O Digital Input Type)

Syntax: !edigintyp or ?edigintyp
Parameter: string of up to 12 characters 0 and 1,
or single bit with two numbers 0 to 11 and 0 or 1

Remarks: Only available with the Multi I/O port of TANGO PCI-E/DT-E.

Description: This instruction sets or reads back if the Multi I/O pull-up / pull-down resistor settings for the 12 inputs. Each of the 12 resistors can be set individually.

0 = pull down
1 = pull up

The pull up/down may be set either by a string of levels (up to 12 0s and 1s) or by specifying the input number and level. The string is LSB first (input 0 is the leftmost).

Response: current pull up/down setting(s)

Examples:

```
!edigintyp 110000000000 Set all pull up/downs (IN0,IN1 to pull up, rest down)
!edigintyp 001 Set IN0+IN1 to pull down, IN1 to pull up, rest left unchanged
!edigintyp 4 1 set IN4 to pull up
!edigintyp 2 0 set IN2 to pull down
?ediginpol read the pull up/down settings of all 12 inputs
?ediginpol 5 read the pull up/down setting of input 5 only
```



17.10. edigoutpreset (Multi I/O Digital Output Presets)

Syntax: !edigoutpreset or ?edigoutpreset
Parameter: string of up to 8 characters 0 and 1,
 or single bit with two numbers: Output 0 to 7 and level 0 or 1

Remarks: Only available with the Multi I/O port of TANGO PCI-E/DT-E.

Description: This instruction sets or reads back the logic levels of one or all digital outputs of the optional Multi I/O extension port, which are applied after power up of the TANGO. Output preset levels may be set either by a string of levels (up to eight 0s and 1s) or by output number and signal level. The string is LSB first (output 0 is the leftmost).

Response: output preset value(s)

Examples:

```
!digoutpreset 11110000  After power on, the digital outputs 0,1,2,3 are set to
                        logic ,1' and the outputs 4,5,6,7 are set to logic ,0'
!digoutpreset 100      After power on, the digital output 0 is set to logic ,1' and
                        the outputs 1 and 2 are set to logic ,0'. Outputs 3 to 7 are
                        left unchanged.
!digoutpreset 5 1      set preset value of output 5 to logic 1 (high)
!digoutpreset 7 0      set preset value of output 7 to 0 (low)
?digoutpreset          read the state of all outputs
?digoutpreset 5        read the state of output 5
```



17.11. adigin (AUX-I/O Digital Input)

Syntax: ?adigin or adigin
Parameter: none or 0 to 3

Description: Available with the AUX-I/O connector.
This instruction returns the logic state of one or all digital inputs on the optional AUX-I/O connector. If no parameter is used all inputs are returned as a string of 4 characters, ASCII 0 or 1, LSB first:

~~0 = Bit 0 = AUX-I/O Pin 1 (Takt In) may not be available!~~
1 = Bit 1 = AUX-I/O Pin 2 (V/R In)
2 = Bit 2 = AUX-I/O Pin 3 (Stop)
3 = Bit 3 = AUX-I/O Pin 4 (SnapShot2)

Response: logic state of digital inputs

Examples:
?adigin read all (4) AUX-I/O digital inputs (response e.g. 1111)
?adigin 3 read AUX-I/O digital input 3 ("SnapShot2", response e.g. 1)

17.12. adigout (AUX-I/O Digital Output)

Syntax: !adigout or ?adigout
Parameter: Set LSB or more bits at once: string of 0s and 1s,
 or single bit with two numbers: 0 to 3 and 0 or 1

Description: Available with the AUX-I/O connector.
This instruction sets or reads back the logic level of the AUX-I/O digital outputs.
Outputs may be set either by a string of levels (0s and 1s) or by individual channel number and signal level:

0 = BIT0 = AUX-I/O Pin 5 (TAKT_OUT) may not be available!
1 = BIT1 = AUX-I/O Pin 6 (VR_OUT)
2 = BIT2 = AUX-I/O Pin 7 (SHÜTTER_OUT)
3 = BIT3 = AUX-I/O Pin 8 (TRIGGER_OUT)

The string is LSB first (channel 0 is the leftmost).

Some outputs might not be available here when trigger modes are activated.

Response: Output state(s), 0 or 1

Examples:
!adigout 1011 Digital outputs 0,2,3 are set to high, output 1 is set to low
!adigout 10 Digital outputs 0 and 1 are set to logic 1(BIT0) and 0(BIT1),
 outputs 2 and 3 are left unchanged
!adigout 1 0 set digital output 1 to logic 0
!adigout 2 1 set digital output 2 to logic 1
?adigout read the level of all outputs (e.g. returns 0000)
?adigout 3 read the level of output 3 (e.g. returns 0)

17.13. anain (Analogue Input)

Syntax: ?anain

Parameter: c (c = channel) or v (higher precision with PCI-E controllers)
0 to 15 (channel number)

Description: This instruction reads the current value of one analogue input channel. The range is decimal from 0 (=0V) to 1023 (=5V).

Channel No	Connector	Pin	Signal Name
0	HDI	1	Joystick X
1	HDI	2	Joystick Y
2	HDI	3	Joystick Z
3	HDI	4	Joystick A
4	HDI	5	Speedpoti
5	HDI	6	IN1B
6	HDI	7	IN2B
7	HDI	8	IN3B
8	HDI	9	IN4B
9	HDI	10	(HDI-ID)
10	AUX-IO	9	ANAINO
11	internal	-	(PSE)
12	internal	-	V-MOT
13	EXT	20	X-ID0
14	EXT	18	X-ID1 / Temp
15	internal	-	REF (2.5V)

To calculate the internal motor voltage:

$$U_{mot}[V] = (5 / 1023) * [anain\ c\ 12] * (55.7/4.7)$$

More accurate:

$$U_{mot}[V] = (2.5 / [anain\ c\ 15]) * [anain\ c\ 12] * (55.7/4.7)$$

To calculate the internal PSE voltage:

$$U_{mot}[V] = (5 / 1023) * [anain\ c\ 11] * (14.7/4.7)$$

More accurate:

$$U_{mot}[V] = (2.5 / [anain\ c\ 15]) * [anain\ c\ 11] * (14.7/4.7)$$

To calculate the case temperature (if available):

$$T[^\circ C] = (250 / [anain\ c\ 11]) * [anain\ c\ 14]$$

Example:

?anain c 10 Read value of channel 10 (analogue input of AUX-IO connector)
==> 510

?anain v 10 Read value of channel 10 (analogue input of AUX-IO connector)
==> 509.75 (response of TANGO PCI-E based TANGO controllers)
==> 510 (response of other TANGO controllers: same as 'c'
for compatibility)

17.14. anaout (Analogue Output)

Syntax: !anaout or ?anaout
 Parameter: 0 to 100 in percent (100% = 10V) for anaout0 and anaout1
 c (c = single channel keyword)
 0, 1 or 2 (single channel number)

Description: Sets or read back the AUX-IO analog output signal levels in percent. It can be accessed in two ways, either direct or a single channel with the 'c' keyword (refer to examples below). The signal resolution is 14 bit with PCI-E and PCI-S based TANGO controllers.
 Power-on presets can be specified to provide a required output voltage after switching on the controller. The functionality can be accessed by the 'p' keyword.

Fractional numbers can be used, 100% corresponds to 10 Volts.

Channel No.	Connector	Pin	Signal Name
0	AUX-IO	10	ANOUT0
1	AUX-IO	11	ANOUT1
2	reserved	-	-

```
!anaout [level of anaout0] [optional also level of anaout1]
!anaout c [channel no.] [level of specified anaout channel]
!anaout p [channel no.] [preset value of specified channel]
```

Remarks: Channel 0 is used for brightness control of the optional LED100 illumination.

Response: Analogue output signal level in percent

Examples:

```
!anaout 100 50.1   Set channel 0 = 100% (10V) and channel 1 = 50.1% (5.01V)
!anaout 75        Set channel 0 = 75% (7.5V)
!anaout c 1 25.3   Set channel 1 to 25.3% (2.53V)
!anaout p 0 10    Set power-on preset value of anaout channel 0 to 10% (1 Volt)
?anaout           Read output level of all channels   (e.g. 0.00 0.00 0.00)
?anaout c 0       Read output level of channel 0 only   (e.g. returns 100.00)
```

17.15. anamode (Analogue Output Mode)

Syntax: !anamode or ?anamode
 Parameter: 0,1,2,3,4

Description: Defines the behavior of the optional analog output, available with the Aux I/O connector. The mode cannot be stored.

- 0 : default mode - output controlled by '!anaout' or by HDI devices in LED100 mode
- 1 : ANOUT0 controled by anain (0~5Vin --> 0~10Vout)
- 2 : ANOUT1 controled by anain (0~5Vin --> 0~10Vout)
- 3 : ANOUT1 controled by Z-axis position (65535 µSteps = 10V)
- 3 : ANOUT1 controled by A-axis position (65535 µSteps = 10V)

Response: Selected mode as integer

Examples: !anamode 3 (set mode 3 to drive analog piezo stage with Z)
 ?anamode ==> 0

17.16. stoppol (Mode and Polarity of Stop Input Signal)

Syntax: !stoppol or ?stoppol
Parameter: 0 to 5 and 8 to 13

Description: Operating mode of the AUX-I/O "Stop" input.
The modes offer selection of high and low polarities as well as different behaviors: stop while signal active, latched stop, HDI remaining enabled or becoming disabled, immediately abort a running move or complete move first then stop.

0,1 Stop only as long as stop signal is applied

HDI (joystick) remains active!

0 : active low

1 : active high

2,3 Stop only as long as stop signal is applied

HDI (joystick) is also disabled

2 : active low

3 : active high

4,5 Stop signal is latched (sticky), must be released by sending a "!stop 0" instruction

HDI (joystick) is also disabled

4 : active low

5 : active high

6,7 Not available

8,9 Same as 0,1 but a running move will be completed first *

10,11 Same as 2,3 but a running move will be completed first *

12,13 Same as 4,5 but a running move will be completed first *

Requirements: A stop signal must be applied for at least 50µs.

***) Stoppol modes 8-13:**

In order to stop, the stop signal must remain active until all axes have finished traveling. If the stop signal is removed while an axis is still traveling, no stop will be performed.

Remarks: Usually the stop input has an internal pull-up resistor to +5V, please refer to the corresponding TANGO operating manual.

If closed loop '**ctrsm**' error condition behavior is set to 4 (latched stop condition), the TANGO controller will set stoppol to a latched mode automatically if this error condition occurs.

Response: Operating mode of AUX-I/O stop signal input as integer

Example:
!stoppol 5 Set the function of the AUX-I/O stop input to latched stop active high.

17.17. stop (Release, Force or Check Stop Condition)

Syntax: !stop or ?stop

Parameter: 0, 1

Description: Release or force a stop condition in latched '**stoppol**' modes 4, 5, 12 and 13. Or read if stop condition is active.

0 = Release stop condition (in stoppol modes 4,5,12,13)

1 = Force stop condition (in stoppol modes 4,5,12,13 only)

Remarks: in stoppol modes 12 and 13, a forced stop by sending "!stop 1" stops the axes immediately (same as in stoppol modes 4,5).

Response: Internal stop state of the controller (0, 1)

Example: !stop 0 release a latched stop
!stop 1 force a stop (in latched stoppol modes only)
?stop read if stop is currently active (=1)

17.18. shutter (Shutter Out Signal of AUX-IO)

Syntax: !shutter or ?shutter

Parameter: 0, 1

Description: Set the AUX-IO shutter out signal to the desired TTL level:

0 = signal low

1 = signal high

Response: Output level of shutter signal

Example: !shutter 1 Set the shutter out signal to TTL high state

17.19. flash (Defined Pulse at AUX-IO Takt Out)

Syntax: !flash or ?flash
Parameter: +-0.00001 ... 32500 [ms]

Description: Sends a pulse of defined length to the AUX-IO TAKT_OUT pin.
Used e.g. for LED strobes.

Floatingpoint numbers in [ms].
Range 0.00001 (10ns) to 32500 (32.5s).
Resolution is 1/132 μ s.

Pulse Polarity depends on sign:

- Positive numbers generate an active high pulse
- negative numbers generate an active low pulse

For safe operation it is recommended to once send one dummy pulse when initializing in order have the correct polarity.

Remarks: **Only available with PCI/PCI-E based controllers and TANGO DT.**
Might interfere with secondary trigger output.

Response: None

Example:
!flash 0.001 (high pulse with duration of 1 μ s)
!flash -0.01 (low pulse with duration of 10 μ s)

18. Encoder Instructions

The encoder interface supports incremental encoders with or without a reference mark. The type of encoder (analog 1Vpp, analog MR or RS422/TTL) should be configured by factory, as it might require a different hardware. For TANGO Desktop and PCI/PCI-E it is possible to switch from any analog (1Vpp or MR) interface to a digital RS422 interface by setting the `encttl` parameter to 1.

To enable encoder functionality, first the **encoder mask** has to be set for the corresponding axes. After that, depending on **calmode**, the encoders (`enc=1`) or also the closed loop will either be activated by calibration of the axis or by power-on.

Manually setting the encoders 'enc' state to 1 is not recommended, as it possibly causes unpredictable behavior in closed loop mode. Also, in case of analog MR encoders, the signal correction will not be performed, which leads to positioning errors.

18.1. encmask (Encoder Mask)

Syntax: `!encmask` or `?encmask`
Parameter: `x, y, z, a` or none
0 or 1

Description: The instruction reads or sets the encoder globally enable mask, which is required to activate the encoders. The encoders then will be detected and activated after a successful calibration instruction '`cal`' or in automatic Closed Loop activation modes (**calmode**) after power up.

0 = clear enable mask (encoder will not be checked/activated)
1 = set enable mask

Response: Encoder enable mask

Example:
`!encmask 1 1 0` Globally enable encoders for X, Y and disable Z-axis
`!encmask z 0` Globally disable encoder for Z-axis
`?encmask` Read encoder mask state of all axes

18.2. enc (Encoder Active)

Syntax: ?enc (or !enc)
Parameter: x, y, z, a or none
 0 or 1

Description: This instruction may be used to query if the encoders are active (e.g. successfully activated by a 'cal' instruction). It is not recommended to manually activate the encoders by sending any of the "!enc 1" instructions. For error free Closed Loop behavior and best measuring accuracy, encoders must be activated by the TANGO controller. This depends on 'calmode', 'cal' and 'encmask'. For further details please refer to the above mentioned instruction descriptions.

0 = Encoder is inactive (not used)
1 = Encoder is active (used)

Response: Encoder active state

Example:
?enc Read encoder active state of all axes
?enc y Read encoder active state of Y-axis
!enc z 0 Disable encoder of Z-axis
!enc 1 1 0 Manually activate encoders of X, Y and disable Z-axis
!enc x 1 Manually activate (not recommended!) the X-axis encoder

18.3. encperiod (Encoder Signal Period)

Syntax: !encperiod or ?encperiod
Parameter: x, y, z, a or none
 0.000002 to 4.0 [mm]

Description: This instruction reads or sets the encoder signal period. The unit is always [mm].

Optional read-resolution: As an option to read the parameter with higher precision, the number of required decimal places can be specified with the query "?encperiod [0...16 decimal places]". If no precision is defined, the default resolution is 4 decimal places.

Response: Encoder signal period(s)

Example:
!encperiod 0.5 0.5 0.001 Set encoder period for X and Y to 500µm, Z to 1µm
!encperiod z 0.02 Set encoder period of Z-axis to 20µm
!encperiod 0.00001960784 Set encoder period of X-axis
?encperiod Read encoder period of all axes
?encperiod z Read encoder period of Z-axis
?encperiod 12 Read period of all axes with 12 fractional digits
?encperiod z 9 Read period of Z-axis with 9 fractional digits

18.4. encdir (Encoder Counting Direction)

Syntax: !encdir or ?encdir
Parameter: x, y, z, a or none
 0 or 1

Description: Encoder counting direction.
Do not set this parameter when closed loop is active!
The encoder direction is set automatically by the TANGO controller before activating the closed loop (e.g. after calibration 'cal' or power-on).
Only if the axis is not used for closed loop (e.g. only for relative distance measuring) the encdir may be set manually.

0 = Encoder counting direction default
1 = Encoder counting direction reversed

Response: Encoder counting direction

Example:
!encdir 1 1 1 Reverse encoder counting direction for all axes
!encdir x 1 Reverse encoder counting direction for X-axis only
?encdir Read encoder counting direction of all axes
?encdir y Read encoder counting direction of Y-axis only

18.5. encvel (Encoder Auto-Adjust Velocity)

Syntax: !encvel or ?encvel
Parameter: x, y, z, a or none
 0.01 ... 20.0 [mm/s]

Description: The velocity for encoder auto-calibration can be set or read by this instruction. It is recommended to keep the default setting. The unit is always [mm/s].

Response: Velocity used for Encoder detection and calibration in [mm/s]

Example:
!encvel 0.5 0.5 0.5 Set encoder auto-adjust velocity for all axes
!encvel 0.5 Set encoder auto-adjust velocity for X-axis only
!encvel z 0.5 Set encoder auto-adjust velocity for Z-axis only
?encvel Read encoder auto-adjust velocity of all axes
?encvel y Read encoder auto-adjust velocity of Y-axis only

18.6. encctl (Encoder has TTL Signal)

Syntax: !encctl or ?encctl
Parameter: x, y, z, a or none
 0 or 1

Description: This instruction reads or sets the type of encoder signal. If digital encoders (A/B-TTL,RS422) are used with an analog encoder interface (configured for 1Vpp or 5Vpp MR), the corresponding encoder has to be set to TTL mode. Else the TTL signal will be found as invalid (due to signal level) and not be used or deactivated during operation (sporadic malfunction).

0 = Encoder has analog sin/cos signals
1 = Encoder has digital quadrature A/B signals (e.g. RS422)

Response: Currently selected encoder signal type(s)

Example:
!encctl 0 0 1 X and Y axis encoders are analog, Z is digital A/B encoder
!encctl z 1 Set Z encoder signal processing to digital
?encctl Query all axes for their currently used signal type
?encctl x Query X-axis for its currently used signal type

18.7. encref (Use Encoder Reference Signal)

Syntax: !encref or ?encref
Parameter: x, y, z, a or none
 0 or 1

Description: Use encoder reference mark. If enabled the '**cal**' instruction will, after reaching the lower limit switch, travel to the reference mark and set the axis position to zero.

0 = Encoder reference signal not used
1 = Encoder reference signal used for calibration

Response: Encoder reference signal used, not used

Example:
!encref 1 1 0 Use encoder reference signal as origin for X and Y-axis
!encref y 1 Use encoder reference signal as origin for Y-axis
?encref Read Encoder reference signal usage of all axes
?encref z Read Encoder reference signal usage of Z-axis

18.8. encnas (Use Encoder NAS Error Signal)

Syntax: !encnas or ?encnas
Parameter: x, y, z, a or none
0 or 1

Description: Before enabling this functionality please make sure that the connected encoder provides a NAS error signal. If enabled, a encoder NAS error also generates an internal 'err' error state. The NAS input signals an encoder error state by a TTL low level.

0 = NAS encoder input state is ignored (default)
1 = NAS encoder input signal is used for extended error detection

Response: Encoder NAS signal used / not used for error detection

Example:
!encnas 1 1 0 Use encoder NAS signal for X and Y-axis
!encnas x 1 Use encoder NAS signal for Y-axis
?encnas Read encoder NAS signal use state of all axes
?encnas x Read encoder NAS signal use state of X-axis

18.9. encrefstatus (Encoder REF Signal State)

Syntax: ?encrefstatus or encrefstatus
Parameter: x, y, z, a or none

Description: Returns the REF signal input state.

0 = REF signal is inactive
1 = REF signal is active (encoder is on a reference mark)

Response: Encoder reference signal state

Example:
encrefstatus Read REF signal state of all axes
encrefstatus x Read REF signal state of X-axis only

18.10. encrefstatusl (Latched Encoder REF Signal State)

Syntax: ?encrefstatusl or encrefstatusl
Parameter: x, y, z, a or none

Description: Returns the latched REF signal input state. If the REF signal was active since last reading of encrefstatusl, a 1 is returned. The corresponding latch state(s) are cleared after reading.

0 = REF signal is/was inactive
1 = REF signal is/was active (encoder is/was on a reference mark)

Response: Latched encoder reference signal state

Example:
encrefstatusl Read+clear latched REF signal state of all axes
encrefstatusl x Read+clear latched REF signal state of X-axis only

18.11. encnasstatus (Encoder NAS Error Signal State)

Syntax: ?encnasstatus or encnasstatus

Parameter: x, y, z, a or none

Description: Returns the NAS error signal input state.

0 = NAS signal is inactive (encoder signals 'no error')

1 = NAS signal is active (error flag is set by encoder)

Response: Encoder NAS error signal state

Example:

encnasstatus Read NAS signal (error) state of all axes

encnasstatus x Read NAS signal (error) state of X-axis only

18.12. encerr (Encoder Error State)

Syntax: !encerr or ?encerr

Parameter: x, y, z, a or none

0

Description: This instruction reads or resets the encoder error state. On error (low signal amplitude '**encamp**', or NAS error flag) the encoder signal is invalid and the closed loop for the corresponding axis is switched off.

0 = No error, normal function

1 = Encoder error

Response: Encoder error state

Example:

!encerr 0 Reset encoder error

?encerr Read encoder error states of all axes

?encerr x Read encoder error states of X-axis only

18.13. encamp (Encoder Signal Amplitude)

Syntax: ?encamp

Parameter: x, y, z, a or none

Optional parameter 1

Description: Read the encoder signal amplitude. 100 (percent) represents the maximum undistorted signal amplitude.

Remarks: In case of single ended TTL encoders the amplitude might be returned as 0.

Response: Encoder signal amplitude in percent as integer

Example:

?encamp Read all encoder signal amplitudes (returns e.g. 57 74 0)

?encamp x Read X encoder signal amplitude

?encamp 1 Read all amplitudes with 1 fractional digit (57.3 73.8 0.5)

?encamp x 1 Read X encoder signal amplitude with 1 fractional digit (57.3)

18.14. encpos (Encoder Position)

Syntax: !encpos or ?encpos
Parameter: x, y, z, a or none
0 or 1

Description: Set or read the position source for a **?pos** instruction. If set to 1 and the encoder is active (corresponding **'enc'=1**), **?pos** returns the encoder position, else the motor position. Refer to the **'pos'** and **'enc'** instructions for further information.

Remarks: For compatibility, sending a 0 or 1 without specifying an axis applies the setting to all axes.

Response: Position output source
0 = pos instruction returns motor position (default)
1 = pos instruction returns encoder position (if enc. active)

Example:
!encpos 1 from now on a **'?pos'** instruction returns the encoder position for all axes (if the corresponding encoders are activated)
~~!encpos 1 1 1~~ Invalid!
!encpos x 1 from now on a **'pos'** instruction returns the encoder position for the X-axis (if the encoder is activated)
?encpos Use not recommended: Due to compatibility this instruction reads the "ored" position output source of all axes (returns just one 0 or 1)
?encpos x Read position output source of X-axis

18.15. hwcount (Hardware Counter)

Syntax: ?hwcount or hwcount
Parameter: x, y, z, a or none

Description: Hwcount returns the position(s) of the independent TTL encoder counter. It is a digital counter that counts the signal slopes (4 per period) and does not provide signal interpolation. So one signal period corresponds to a counter reading of 4. Also refer to the **'clearhwcount'** instruction.

Response: Encoder hardware counter value(s)

Example:
hwcount Returns the position counter of all axes
hwcount x Returns the position counter of X-axis only

18.16. clearhwcount (Clear Hardware Counter)

Syntax: !clearhwcount or clearhwcount
Parameter: x, y, z, a or none

Description: Reset the hardware counter(s) to zero.

Response: Reset encoder hardware counter value(s)

Example:
clearhwcount Reset hwcount position of all axes to zero
clearhwcount x Reset hwcount position of X-axis to zero

19. MR Encoder Instructions

19.1. mra (MR Amplitude Correction Factor)

Syntax: !mra or ?mra
Parameter: x, y, z, a or none
0.8 to 1.2

Description: This instruction reads or sets the cosine amplification correction factor of the analogue encoder signal (here: sin/cos amplitude ratio). This factor is calculated automatically on each calibration move 'cal' and should not be changed. If the axis is manually controlled and only used for relative measurement, so that no 'cal' is possible, the user may determine the ratio itself and then write it into mra for more accurate results. Please also refer to the 'mro' instruction.

Response: Currently used correction factor(s)

Example:
?mra Read MR signal correction factor of all axes
?mra x Read MR signal correction factor of X-axis only
!mra x 1.0095 Amplify the X cosine signal by *1.0095 compared to the sine

19.2. mro (MR Offset Correction Value)

Syntax: !mro or ?mro
Parameter: x, y, z, a or none
-2048 to +2048

Description: This instruction reads or sets the sine and/or cosine offset compensation value as 16bit signed digits. This factor is calculated automatically on each calibration move 'cal' and should not be changed. If the axis is manually controlled and only used for relative measurement, so that no 'cal' is possible, the user may determine the offset itself and then write it into mro for more accurate results. Please also refer to the 'mra' instruction.

Response: Currently used correction values

Example:
?mro Read MR signal offset value sine and cosine for all axes
?mro x Read MR signal offset value sine and cosine for X-axis only
!mro 48 -100 0 0 0 0 0 Set X offset to sin=48digit, cos=-100digit, Y, Z = 0
!mro y 16 -28 Set Y offset to sin=16digit, cos=-28digit
!mro y 16 Set only sine offset of Y encoder

19.3. mrp (MR Signal Peak-To-Peak Measuring Result)

Syntax: !mrp or ?mrp
Parameter: x, y, z, a or none
-2048 to +2048

Description: This instruction reads or sets the sine and/or cosine peak values, measured since they were reset the last time. It is just a measurement and has no effect to the signal processing itself. The returned values are signed 16bit digits.

Response: [sine max] [sine min] [cosine max] [cosine min] result(s)

Example:

```
?mrp x Returns [x_sin max] [x_sin min] [x_cos max] [x_cos min]
?mrp Returns the above, but for all axes (up to 16 values)
!mrp x 0 0 0 0 Reset the peak-to-peak measurement for x
!mrp x 0 0 Reset only the X sine min, max values
!mrp 0 0 0 0 0 0 0 0 0 0 0 0 0 0 0 0 Reset measurement for all 4 axes
```

19.4. mrt (MR Signal Level)

Syntax: ?mrt
Parameter: x, y, z, a or none
1 to 32767 and -1 to -32767

Description: This instruction reads the corrected sine and cosine A/D converter results of the analog encoder interface as signed 16 bit integer.

in case of MR encoders, specifying a negative number returns the corrected analog value (offset, amplitude).

The number of data samples (lines) to read should be specified, e.g. '?mrt 1' for returning one sample. If there is no number specified, the instruction returns 10 sampling results per default.

Response: [sine] [cosine] results as signed 16 bit values
or [x_s] [x_c] [y_s] [y_c] [z_s] [z_c] for all
Each data line is terminated by a [CR].

Example:

```
?mrt Returns 10 lines with all axes (up to 6 values per line)
?mrt 1 Returns one line with all axes (up to 6 values)

?mrt x Returns 10 lines with [x_sin] [x_cos] signal digits
?mrt x 1 Returns one line with [x_sin] [x_cos] signal digits
?mrt y 2 Returns two lines with [y_sin] [y_cos] signal digits
?mrt y 1000 Returns 1000 lines with [y_sin] [y_cos] signal digits

?mrt -1 Returns one line, all axes with MR correction applied
?mrt x -10 Returns 10 lines, X axis with MR correction applied
```

20. Closed Loop Instructions

The closed loop control positions the axis to the measuring system position. So the inaccuracy of the drive is compensated. The closed loop control circuit is activated by the "ctr" instruction. Also the encoder(s) require the enable request "encmask" to be set. To enter the closed loop, either a calibration "cal" has to be executed or the power-up modes have to be set to **calmode** 1 or 2.

Remarks:

For successfully enabling the closed loop (use the "ctrstatus" instructions to check if it is active) it is necessary to have the correct **pitch**, **gear** and **encperiod** settings. The detection tolerance of these parameters is about a factor of 2, else the closed loop will not be activated.

The closed loop target window (**twi**, in combination with **ctrd**, **ctrtr**) is the condition for identifying if the axis has reached its target position. In the default closed loop mode (**ctr** = 2) the axis then will still try to get/stay precisely at the target position, independent of the window size.

When the optional motor current "**reduction**" is set below 0.3 (30%), closed loop will be disabled during reduction (axis has stopped and **curdelay** has expired).

20.1. ctr (Control Enable)

Syntax: !ctr or ?ctr
Parameter: x, y, z, a or none
 0,1,2,3,4

Description: This instruction activates the closed loop circuit.
 0 = Closed Loop OFF
 1 = Closed Loop Auto OFF each time position is reached
 2 = Closed Loop always ON (default, recommended)
 3 = (currently not supported!)
 4 = (currently not supported!)

Response: Closed loop state(s)

Examples:

```
!ctr 0 0 0 0      Closed loop off for all axes
!ctr 2 2          Closed loop for X- and Y-axis permanently on
!ctr z 1          Closed loop for Z-axis switches off after position reached
?ctr              Read closed loop states of all axes
?ctr x            Read closed loop state of X axis
```

20.2. ctrf (Control Factor)

Syntax: !ctrf or ?ctrf
Parameter: x, y, z, a or none
0.0 to 25.0

Description: CTRF IS FOR COMPATIBILITY ONLY - PLEASE USE CTRFF.
This instruction reads or sets the closed loop factor.
Higher values result in more stiffness and faster settlement.
Above a critical value this may lead to oscillation.
The default factor of 2.0 mostly results in a good behavior.
Hint: Using the ctrff instruction instead offers more options.

Remarks: Even if setting the parameter supports floating point, the return value is integer (for compatibility).
It is recommended to use ctrff instead of ctrf.

Response: Closed loop factors as integers (rounded)

Examples:
!ctrf 2 2 2 Set closed loop factor to 2 for all axes
!ctrf x 3 Set closed loop factor for X axis to 3
?ctrf Read closed loop factors of all axes (as integer)
?ctrf y Read closed loop factor of Y axis (as integer)

20.3. ctrff (Extended Control Factor)

Syntax: !ctrff or ?ctrff
Parameter: x, y, z or a
0.0 to 25.0
0.0 to 25.0

Description: This instruction reads or sets 2 closed loop factors per axis.
Higher values result in more stiffness and faster settlement.
Above a critical value this may lead to oscillation.
The default factor of 2.0 mostly results in a good behavior.
Important: Can only be set per axis (with x,y,z,a parameter)!

Parameter1: Is used while axis is moving
Parameter2: Is used when axis is stopped/idle

Parameter 2 can be set to higher values than Parameter1 to achieve smoother axis travel while still having the stiffness and faster settling times at the end of a move.
(E.g.: "!ctrff x 2 4".)

Response: Closed loop factors (2 per axis)

Examples:
~~!ctrff 2 2 2 2~~ Not supported!
!ctrff x 2 4 Set closed loop factors for X axis 2(moving) and 4(reached)
?ctrff Read closed loop factors of all axes (2 parameters per axis)
?ctrff y Read closed loop factors of Y axis only (2 parameters)

20.4. ctrc (Control Call)

Syntax: !ctrc or ?ctrc
Parameter: 1 to 100 [ms]

Description: This instruction reads or sets the controller call interval. Unit is milliseconds. Only one parameter for all axes. The default interval of 5 [ms] in most cases leads to the best results. Values of less than 3 [ms] are not recommended.

Response: Closed loop control call interval in milliseconds.

Examples:
!ctrc 5 Closed loop control is executed every 5 milliseconds
?ctrc Read closed loop call interval

20.5. ctrd (Control Target Window Delay)

Syntax: !ctrd or ?ctrd
Parameter: 0 to 1000 [ms]

Description: This instruction reads or sets the control delay, which is used as a position reached criteria when in closed loop mode. The closed loop has to remain inside the target window (**twi**) for this time, until the position reached state is set. If the target window is left before the delay time is over, the time starts counting again. Please also refer to the **ctrtr** timeout, which aborts the waiting for **twi+ctrd** after a certain amount of time.

The unit is milliseconds. Only one parameter for all axes.

Response: Closed loop control delay in milliseconds.

Examples:
!ctrd 100 Closed loop controller must be in target window for 100 ms
?ctrd Read closed loop target window delay

20.6. ctrtr (Control Timeout)

Syntax: !ctrtr or ?ctrtr
Parameter: 0 to 10000 [ms]

Description: This instruction reads or sets the control timeout. It specifies the maximum time the closed loop tries to reach the desired encoder position. If the **ctrd+twi** condition could not be fulfilled within this **ctrtr** time, it will be aborted. If **ctrd/ctrtr** is used, the **ctrtr** timeout must be set to a value which is higher than the **ctrd**, typically 1 or more seconds. Unit is milliseconds. Only one parameter for all axes.

Response: Closed loop control timeout in milliseconds.

Examples:
!ctrtr 1000 Closed loop tries to reach the end position for 1 second
?ctrtr Read closed loop timeout

20.7. twi (Target Window)

Syntax: !twi or ?twi
Parameter: x, y, z, a or none
 [value corresponding 0.00001 to 1 mm] in dim units

Description: This instruction reads or sets the closed loop control target window width (+-). While increasing this value leads to position variance, setting a too narrow window may result in oscillation and closed loop timeouts (higher ctrd,ctrtr values necessary).
 The unit depends on 'dim'.

Response: Closed loop target window.

Examples:

```
!twi 0.001 0.001  Closed loop target window +-1µm (if dim=2) for X and Y-axis
!twi y 0.005      Closed loop target window +-5µm (if dim=2) for Y-axis
?twi              Read target window of all axes
?twi z           Read target window of Z-axis only
```

20.8. ctrsm (Control behavior outside Lock-in Range)

Syntax: !ctrsm or ?ctrsm
Parameter: x, y, z or none

Description: Behavior of the closed loop circuit when outside the lock-in range (**ctrs**).
 When outside defined ctrs lock-in range, which is regarded to be an error, the TANGO controller can treat this condition as follows:

- 0 = Do nothing (default)
- 1 = Limit the closed loop velocity (avoid stalling the motor)
- 2 = Disable closed loop until returning to lock-in range
- 3 = Disable closed loop permanently
- 4 = Axis is set to latched stop condition (read remarks)**
- 5 = Switch off all power stages (like !pa 0)

Remarks: ** **stoppol** is manipulated by this function in order to achieve a latched stop (stoppol value is or'ed by 4).
 The stop condition must be released by sending "**!stop 0**"

Response: Selected Behavior of the axes as integer

Examples:

```
!ctrsm z 1        Select slow mode in Z (to avoid stalling of the motor)
!ctrsm 5 5 5      Select switch off mode for safety (e.g. collision detection)
?ctrsm           Read all behaviors
?ctrsm y         Read behavior of Y-axis only
```

20.9. ctrs (Control Lock-in Range)

Syntax: !ctrs or ?ctrs
Parameter: x, y, z or none
 0.01 [mm] to [maxpos]

Description: Lock-in range of the closed loop circuit.
 When the closed loop position difference exceeds this limit,
 the behavior defined with **ctrsm** is applied to the axis/axes.
 The unit depends on '**dim**'.

Response: Closed loop lock-in range.

Examples:

```
!ctrs 0.5 0.5 0.2 Set lock-in range of X=0.5mm, Y=0.5mm, Z=0.2mm (if dim=2 or 9)
!ctrs z 0.1      Set lock-in range of Z=0.1mm (if dim= 2 or 9)
?ctrs           Read lock-in range of all axes
?ctrs z        Read lock-in range of Z-axis only
```

20.10. ctrstatus (Control Status)

Syntax: ?ctrstatus
Parameter: x, y, z, a or none
optional parameter: 1, 2 or 3

Description: Read the internal closed loop states of the specified or all axes. Options and responses are:

A) Called without parameter:

Returns the internally applied **ctr** state which is set when the closed loop gets enabled by the controller (!cal or calmode=1,2).

- 0 Closed loop permanently off
- 1 Closed loop only active while moving
- 2 Closed loop always on (default closed loop operation)
- (3 Closed loop only active while moving)
- (4 Closed loop always on)

B) Called with parameter "1":

Check if the closed loop is currently active.

- 0 = Closed loop not active
(e.g. ctr=0, !cal running, encerr, limit swich, etc.)
- 1 = Closed loop active

C) Called with parameter "2":

Check if closed loop is in target window.

- 0 = Position outside target window
- 1 = Position in target window

A) Called with parameter "3":

Check if closed loop is in lock-in range.

- 0 = Position outside lock-in range
- 1 = Position in lock-in range

Response: Closed loop state.

Examples:

```
?ctrstatus Returns the internally running ctr mode of all axes
?ctrstatus y Returns the internally running ctr mode of the Y-axis

?ctrstatus 1 Returns the Closed Loop active state of all axes, e.g. "1 1 0"
?ctrstatus x 1 Returns the Closed Loop active state of the X-axis, e.g. "1"

?ctrstatus 2 Returns if Closed Loop is in target window, e.g. "1 1 0"
?ctrstatus z 2 Returns if Closed Loop of the Z-axis is in target window

?ctrstatus 3 Returns if Closed Loop is in lock-in range, e.g. "1 1 0"
?ctrstatus z 3 Returns if Closed Loop of the Z-axis is in lock-in range
```



20.11. ctrdiff (Control Position Difference)

Syntax: ?ctrdiff

Parameter: x, y, z, a or none

Description: This instruction returns the momentarily measured closed loop position difference between the motor and encoder position (mot.pos - enc.pos). The unit depends on **dim** settings.

Response: Momentary position difference.

Examples:

?ctrdiff Returns the position difference of all axes

?ctrdiff y Returns the position difference of the Y-axis e.g. "0.0015"

21. Trigger Output Functionality (option)

Trigger functionality must be configured by factory.

To identify if the Trigger functionality is accessible, use `'?det'` or `'detext'`.

The optional trigger output generates TTL signals dependend on axis positions or as a constant frequency. It can be used to synchronize external devices like e.g. a camera. TANGO Desktop and PCI/PCI-E controllers provide up to 2 trigger outputs via the optional AUX-I/O connector. See **mode** and **output description**. Also positions and analog values can be captured by adding **SnapShot Mode 8**.

Before enabling the trigger function (by `'!trig 1'`), please make sure that all trigger settings have been made.

```
Example1:  !trig 0[CR]           Disable trigger
           !trigm 0[CR]        Choose trigger mode 0
           !triga x[CR]        Choose X axis as trigger source
           !trigd 0.100[CR]     Set trigger distance to 100µm (if dim = 2)
           !trigs 400[CR]       Set trigger pulse width to 0.4ms
           !trig 1[CR]         Enable trigger and set start position
```

```
Example2:  !trig 0[CR]           Disable trigger
           !trigs 120[CR]        Set trigger pulse width to 120µs
           !trigf 2500[CR]       Set pulse frequency to 2.5kHz
           !trigm 100[CR]        Choose trigger mode 100 (periodic signal)
           !trig 1[CR]         Enable trigger
```

Optional `"trigcount 0"` instruction may be executed to reset the event counter.

21.1. trig (Trigger)

```
Syntax:      !trig or ?trig
Parameter:   0 or 1
```

Description: This instruction enables or disables the trigger circuit. `"!trig 1"` also sets the trigger start position.

0 = Trigger function globally disabled
1 = Trigger function globally enabled

```
Response:    0 or 1
```

```
Examples:
!trig 1      Enable trigger circuit (also defines the start position)
?trig       Read enable state of trigger circuit
```

21.2. triga (Trigger Axis)

```
Syntax:      !triga or ?triga
Parameter:   x, y, z or a
```

Description: This instruction selects the axis on which to trigger.

```
Response:    x, y, z or a
```

```
Examples:
!triga y     Select Y-axis as trigger source
?triga       Read current trigger axis
```

21.3. trigm (Trigger Mode)

Syntax: !trigm or ?trigm
 Parameter: 0 to 11, 100 to 105

Description: This instruction selects the required trigger mode.

Trigger Mode	Trigger Generation	Trigger Signal	Remarks
0		High active	First pulse when move starts <i>Direction forward</i>
1		High active	First pulse when move starts <i>Bidirectional</i>
2		High active	First pulse when move starts <i>Direction backward</i>
3	-- See Mode 0 --	Low active	Same as 0, signal inverted
4	-- See Mode 1 --	Low active	Same as 1, signal inverted
5	-- See Mode 2 --	Low active	Same as 2, signal inverted
6		High active	Triggers shifted by $\text{trigd}/2$ <i>Direction forward</i>
7		High active	Triggers shifted by $\text{trigd}/2$ <i>Bidirectional</i>
8		High active	Triggers shifted by $\text{trigd}/2$ <i>Direction backward</i>
9	-- See Mode 6 --	Low active	Same as 6, signal inverted
10	-- See Mode 7 --	Low active	Same as 7, signal inverted
11	-- See Mode 8 --	Low active	Same as 8, signal inverted
100	Periodic trigger signal the frequency can be set by "trigf" instruction	High active	Does not depend on position
101		Low active	
102	Manually forced trigger signals by the "trigger" instruction	High active	Does not depend on position or time
103		Low active	
104	Position reached trigger signal if all moves including the specified axis "triga" have completed	High active	Comes with the "@@@" autostatus response
105		Low active	



Response: Trigger mode as integer: 0 to 11, 100 to 105

Examples: !trigm 0 Set Trigger Mode 0
 ?trigm Read current trigger mode

21.4. trigo (Trigger Output)

Syntax: !trigo or ?trigo
 Parameter: 0 to 15

Description: This instruction selects the trigger outputs.

The secondary (TAKT_OUT) output provides high precision delay, width or frequency via the trigb... instructions.

A combined delay and width, in 40µs steps, is available with PCI-E based controllers only. (!trigs instruction, please refer to **chapter explaining the second trigger output.**)

Output / Mode	STANDARD	PREC.WIDTH2	PREC.DELAY2	PREC.FREQUENCY2
No output No signal out	0	(4)	(8 PCI-E)	(12)
Primary TRIGGER_OUT	1	(5)	(9 PCI-E)	(13)
Secondary TAKT_OUT	2	6	10 (PCI-E)	14
Both TRIGGER+TAKT	3	7	11 (PCI-E)	15

For further information of the second trigger output, please refer to **trigbwidth**, **trigbdelay**, **trigbf** and the description of the **second trigger signal output**.

Remarks: Options depend on hardware: TANGO PCI-E / DT-E based controllers with AUX-IO connector offer all features. PCI-S based controllers do not provide the precision Delay function and TANGomini provides none or one output.

Response: Selected trigger outputs

Examples: !trigo 0 No output signal
 !trigo 1 Default trigger output (TRIGGER_OUT)
 !trigo 2 Secondary trigger output (AUX-IO TAKT_OUT)
 !trigo 3 Both trigger outputs 1:1 (TRIGGER_OUT and TAKT_OUT)
 ?trigo Read selected trigger output

21.5. trigs (Trigger Signal Length)

Syntax: !trigs or ?trigs
Parameter: 0 to 2500000 [μ s]

Description: This instruction is used to adjust the trigger pulse width from 40 microseconds to 2.5 seconds in increments of 40. (0 = shortest trigger signal width, narrow pulse)
If the parameter is not a multiple of 40 it will be rounded to the next lower multiple (e.g. 100 --> 80). When read back, the corrected value is returned (here: 80).

Response: 0 to 2500000 (μ s)

Examples:
!trigs 40 Set Trigger pulse width to 40 μ s
!trigs 2500000 Set Trigger pulse width to 2.5 s
?trigs Read current trigger pulse width

21.6. trigd (Trigger Distance)

Syntax: !trigd or ?trigd
Parameter: >0.0 to 5000000 (unit depends on **dim** of the selected axis)

Description: This instruction sets the required trigger distance. After passing this position interval of trigd with the selected axis, a trigger signal is generated.

Response: Trigger distance

Examples:
!trigd 3.01 Set trigger distance to 3.01mm (if dim of selected axis is 2)
?trigd Read current trigger distance

21.7. trigcomp (Trigger Compensation)

Syntax: !trigcomp or ?trigcomp
Parameter: -10000 ... +10000 [μ s] (smallest step is 10 μ s)

Description: Delay compensation for position trigger (look ahead) to avoid stitching mismatch with bidirectional scan applications.

At high velocity "on the fly" scans, the delay of the trigger signal chain has an effect on where the sample was taken. When scanning in both directions this effect becomes visible (e.g. comb-like appearance of the stitched image). This can be greatly improved or entirely removed by increasing the delay compensation. The delay added by the TANGO already is internally compensated, so the default setting is 0.

Remarks: Also check if the scan axis has a mechanical backlash, which can be compensated for open loop applications by using the backlash instruction.

Response: Compensated delay in [μ s]

Examples:
!trigcomp 130 Compensate trigger signal chain delay of 130 μ s
?trigcomp Read the compensation delay (e.g. returns 0)



21.8. trigenc (Trigger on Encoder)

Syntax: !trigenc or ?trigenc
Parameter: 0 or 1

Description: Trigger position source select, encoder or motor position.

0 = Trigger position from motor position (default)
1 = Trigger position from encoder (true position)

Remarks: Encoder position is only used when encoders are active.

Response: Currently selected trigger position source

Examples:
!trigenc 1 Trigger based on the encoder signal
?trigenc Read the trigger position source

21.9. trigf (Trigger Frequency)

Syntax: !trigf or ?trigf
Parameter: 0.01 to 25000

Description: This instruction sets the frequency for periodic trigger
output mode (trigm 100).
The frequency resolution is 1/40 μ s.

Response: Trigger frequency

Examples:
!trigf 2500 Periodic trigger pulses have 2.5kHz (signal every 0.4ms)
?trigf Read trigger frequency

21.10. trigbdelay (Precise Trigger Delay for second output)

Syntax: !trigbdelay or ?trigbdelay
Parameter: 0.00 to 32500000 [µs]

Description: Precise delay for secondary trigger output signal (TAKT_OUT). Applies to trigger output settings !trigo 10 and 11. Unit in microseconds [µs], resolution is 1/132µs.

Remarks: Secondary trigger can either have precise width or delay.
Only available with TANGO PCI-E based controllers.

Response: Delay time in µs

Examples:

```
!trigbdelay 0.35 Delay the secondary trigger signal by 350ns (to TRIGGER_OUT)
?trigbdelay      Read the secondary trigger delay (e.g. returns 0.00)
```

21.11. trigbwidth (Precise Signal Width for second output)

Syntax: !trigbwidth or ?trigbwidth
Parameter: 0.00 to 32500000 [µs]

Description: Precise width for secondary trigger output signal (TAKT_OUT). Applies to trigger output settings !trigo 6 and 7. Unit in microseconds [µs], resolution is 1/132µs.

Remarks: Secondary trigger can either have precise width or delay.
Only available with TANGO PCI/PCI-E based controllers.

Response: Signal width in µs

Examples:

```
!trigbwidth 5.01 Set secondary trigger signal width to 5.01µs
?trigbwidth      Read the secondary trigger signal length (e.g. returns 40.00)
```

21.12. trigbf (Precise Trigger Frequency for second output)

Syntax: !trigbf or ?trigbf
Parameter: 0.010 ... 66000000 [Hz]

Description: Precise frequency for secondary trigger output (TAKT_OUT). Applies to trigger output settings !trigo 14 and 15. Unit in microseconds [µs], resolution is 1/132µs.

Remarks: **Only available with TANGO PCI/PCI-E based controllers.**
Trigcount does not count the precise trigger events.

Response: Output frequency [Hz] for precise frequency output mode.

Examples:

```
!trigbf 0.01      Set secondary trigger frequency to 0.01Hz
!trigbf 50000005 Set secondary trigger frequency to 50.000005 MHz
?trigbf          Read the secondary trigger frequency (e.g. returns 1000.000)
```



21.13. trigcount (Trigger Counter)

Syntax: !trigcount or ?trigcount
Parameter: 0 to 2147483647

Description: This instruction reads or sets the trigger event counter.

Response: Number of executed triggers

Examples:

?trigcount Read trigger count
!trigcount 0 Clear trigger counter
!trigcount 110 Set trigger counter to 110 counted events

21.14. trigger (Force Trigger Signal)

Syntax: !trigger or trigger
Parameter: None

Description: This instruction generates a trigger output pulse. It is available in manual forced trigger modes 102 and 103 only. The pulse width depends on the "**trigs**" setting.

Response: None

Examples: trigger (Force trigger pulse now)

21.15. trigr (Set Trigger Range)

Syntax: !trigr or trigr
Parameter: x, y, z, a or none
start position
end position
number of equidistant trigger signals within the range

Description: Provides a special trigger mode which begins and ends at defined positions, generating equidistant trigger signals. No trigger mode has to be defined, trigr sets it automatically. The function is unidirectional.

If no axis is specified, the trigger axis is used (?triga).
If an axis is specified (x,y,z,a) the trigger axis is set to this axis.

Trigger signals are generated within a position range.
The axis direction is set by the start/end positions:
- start < end = trigger in positive travel direction
- start > end = trigger in negative travel direction

Start and end positions are specified as floating point in the currently used position unit (**dim**), e.g. mm.

The number of trigger signals defines the distance:
The first trigger is generated at the start position and the last trigger is generated at the end position (n+1).
e.g. to achieve 1mm distance from 0 to 10 mm = 11 signals.

Once set, the trigger range remains and is reactivated automatically when the axis travels back behind the start position. If required, the !trigr can be specified with new parameters ahead of any move instruction.

For bidirectional scans, !trigr must be set to the required travel direction before each move.
The move must start from below the start position and travel Past the end position.

Response: Currently set parameters: [startpos] [endpos] [range]

Examples:

- Preparing the axis:

```
( !trigenc 1 )      (optional: if the axis provides encoder)
!triga x           (can also be specified/updated with !trigr)
```

- Trigger in positive direction:

```
!moa 9             (move X to position below the trigger range)
!trigr 10 20 11   (one trigger every mm, 10,11,12,...20)
!trig 1
!moa 21           (move X to position past the trigger range)
```

- Trigger in negative direction:

```
!moa 21           (move X to position below the trigger range)
!trigr 20 10 11   (one trigger every mm, 20,19,18,...10)
!trig 1
!moa 9            (move X to position past the trigger range)
```

?trigr ==> 20.0000 10.0000 11

22. The Second Trigger Signal Output

22.1. Introduction

PCI/PCI-S/PCI-E and Desktop TANGOs provide two trigger output signals. Only PCI-E based controllers support all functionality described in this chapter.

Depending on the trigger mode, the output signals are active high or active low. This description shows the trigger signals in active high mode.

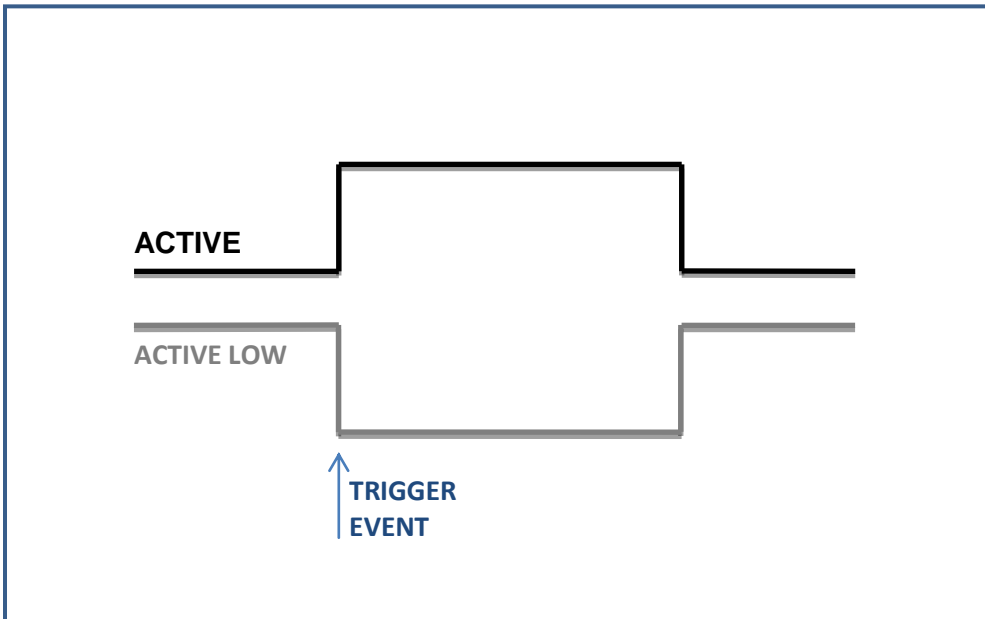

Up to two output signals are available and can be selected with the `'trigo'` instruction:

- TRIGGER_OUT (here called OUT1)
- TAKT_OUT (here called OUT2)

OUT2 is provided by PCI and Desktop TANGOs only.

Both outputs share the same polarity setting and trigger source.

The optional LED100 illumination uses OUT2.

If the OUT1 signal width is set to zero a short spike still is generated, allowing the edge to trigger events of up to 25 kHz. The minimum OUT1 width of 40µs results in 12.5 kHz max. signal frequency.

22.2. Standard 1:1

Signal: OUT2 provides the same signal as OUT1 (refer to OUT1 options)

Options: When the signal width (trigs) instruction is sent with 3 parameters, OUT2 provides the option of a delay and individual width. OUT2 signal becomes inactive latest when OUT1 returns into inactive state.

Remarks: Can be used with any trigger mode of OUT1.
 Parameter in multiples of 40µs (0; 40; 80; ... 2,500,000)
 Possible jitter up to a few microseconds

Application: Commonly used with camera and shutter/LED applications

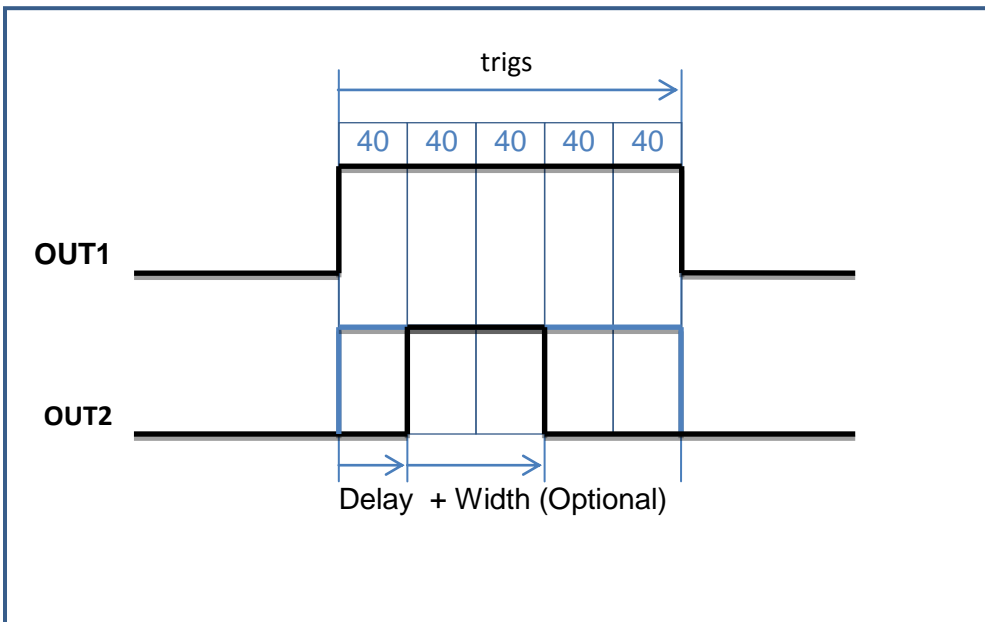

OPTIONS

- `!trigo 1` → OUT1 only, OUT2 set to inactive level
- `!trigo 2` → OUT2 only, OUT1 set to inactive level
- `!trigo 3` → OUT1 and OUT2

EXAMPLE

- `!trigo 3`
- `!trigs 200 40 80` → Set OUT1 signal width & maximum duration (200µs), Delay (40µs) and Width (80µs) for OUT2
- or `!trigs 200` → Set OUT1 and OUT2 signal width to 200µs

22.3. Precise Width

Signal: OUT2 starts with OUT1 but has individual, high resolution width.

Remarks: Can be used with any trigger mode of OUT1.
OUT2 resolution is in 7.6ns steps, up to 32.5 seconds.
OUT2 width can be longer than OUT1.

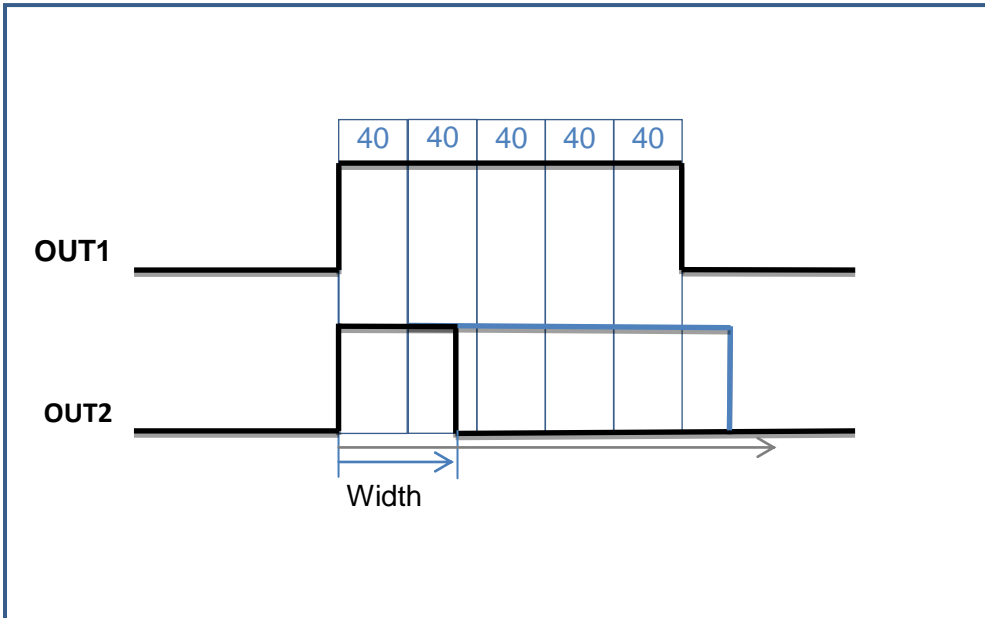

OPTIONS

`!trigo 5` → OUT1 only, OUT2 set to inactive level
`!trigo 6` → OUT2 only, OUT1 set to inactive level
`!trigo 7` → OUT1 and OUT2

EXAMPLE

`!trigo 7`
`!trigs 200`
`!trigbwidth 65.4` or `!trigbwidth 230`

22.4. Precise Delay

Signal: OUT2 provides a precise edge delay to OUT1.

Remarks: Can be used with any trigger mode of OUT1.
 OUT2 resolution is in 7.6ns steps, up to 32.5 seconds.
 OUT2 delay can be later as the OUT1 signal width.
 Very low jitter between the two edges OUT1 - OUT2 (<10ns).
 The OUT2 pulse width can't be specified, it is resetted in 40µs intervals. Pulses of 100ns up to 39µs may occur.

Application: Precise trigger of transducer and receiver

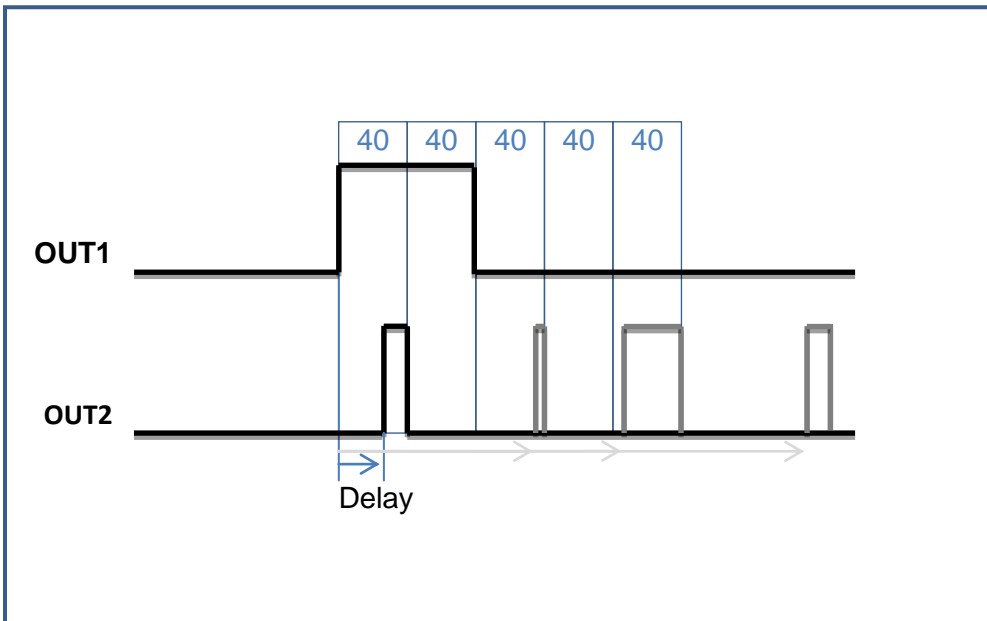

OPTIONS

- `!trigo 9` → OUT1 only, OUT2 set to inactive level
- `!trigo 10` → OUT2 only, OUT1 set to inactive level
- `!trigo 11` → OUT1 and OUT2

EXAMPLE

```
!trigo 11
!trigs 80
!trigbdelay 25.5 or !trigbdelay 112.03 or !trigbdelay 165
```

22.5. Precise Frequency

Signal: OUT1 and OUT2 provide individual output frequencies.

Remarks: OUT1 can run in an individual trigger mode (position dependent, etc.)
 OUT1 width can be specified by `'trigs'`
 OUT1 frequency is limited to 0.01 to 25000 Hz and 1/40µs resolution
 OUT2 provides 0.010...66,000,000 Hz high resolution and low jitter
 OUT2 has fixed width of 50%
 OUT1 and OUT2 are in phase if the frequencies match (multiples)

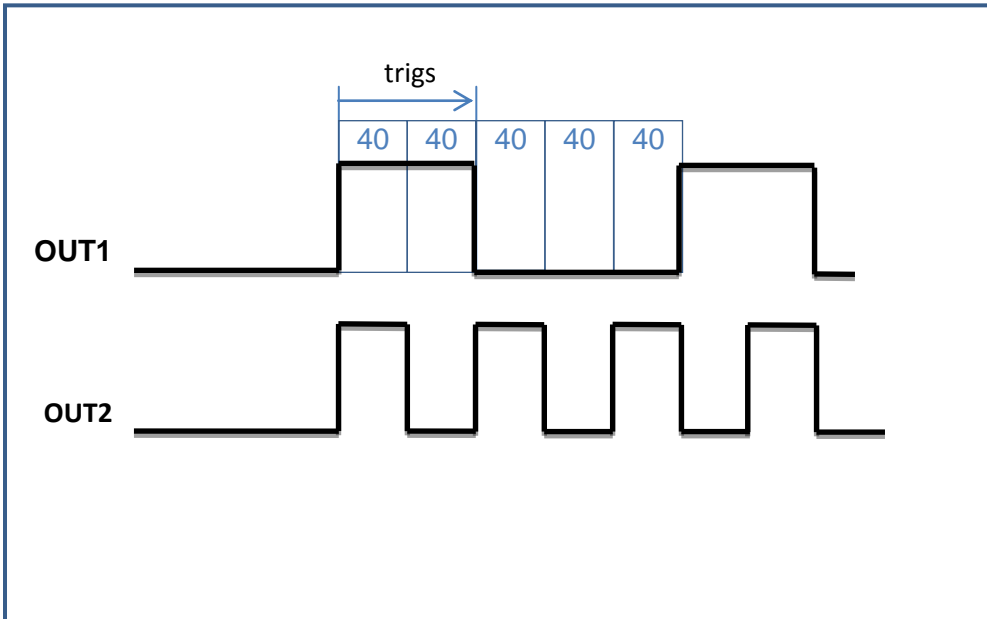

OPTIONS

```
!trigo 13 → OUT1 only, OUT2 set to inactive level
!trigo 14 → OUT2 only, OUT1 set to inactive level
!trigo 15 → OUT1 and OUT2
!trigm can be set to an independent behavior, must not be frequency output
```

EXAMPLE

```
!trigo 15
!trigs 80
!trigf 5000
!trigbf 12500
!trigm 100
```

23. Snapshot -Trigger Input Functionality (option)

Snapshot functionality must be configured by factory.

To identify if the Snapshot functionality is configured, use `?det` or `detext`.

The snapshot functionality allows capturing of X,Y,Z,A axis positions by either pressing a HDI key (e.g. Joystick F2), an external signal or a trigger-out event. Hardware dependent, analog input signals from the AUX I/O connector are captured as well. The values are appended to the snapshot array. The snapshot array can also be filled, extended or manipulated by `snsa`, `!snp` instructions.

A snapshot event can command the TANGO controller to move to positions stored in the snapshot array (`snsm 1,5`). Every snapshot event moves to the next array entry and wraps around at the end. It can i.e. be used to review memory positions (points of interest) stored in `snsm 0,4` before.

Snapshot can also start a move (`moa,mor,speed,go`) instruction, refer to `snsm 6`.

The snapshot event can be triggered by either

A) the Joystick key F2

B) via the SnapShot signal input (depends on hardware, AUX I/O connector option)

C) by a software instruction (`sns`)

Please refer to `snsm` for available snapshot modes.

The position unit depends on the selected dimension (`dim`). The setting of `encpos` defines if the motor position or the measured encoder position is read from the array. A maximum of 1024 snapshot positions can be captured.

For changing the snapshot configuration please disable the snapshot (`!sns 0'`) and then re-enable it (`'!sns 1'`) after all settings have been made.

Remarks:

Most of the snapshot settings can not be stored permanently to the controller.

Requirements:

The TANGO controller must be ordered with this function enabled, as it is not available by default or might require additional hardware (e.g. connector).

The snapshot signal must have an active and inactive time of at least 200µs each. Else the signal may not be recognized by the controller. Refer to `'snsf'`.

Example: Three snapshot positions are captured with a 3 axis TANGO

Index	Position X	Position Y	Position Z	Position A
1	1.0000	1.2345	1.2345	0
2	2.1200	1.3520	0.9343	0
3	3.5900	1.9000	0.8341	0
4	<i>invalid</i>	<i>invalid</i>	<i>invalid</i>	<i>invalid</i>
5	<i>invalid</i>	<i>invalid</i>	<i>invalid</i>	<i>invalid</i>

...

1024	<i>invalid</i>	<i>invalid</i>	<i>invalid</i>	<i>invalid</i>
------	----------------	----------------	----------------	----------------

Here: `?snc --> 3 ?nsa 2 --> 2.1200 1.3520 0.9343 ?nsa y 1 --> 1.2345`

23.1. sns (Snapshot enable/disable)

Syntax: !sns or ?sns
Parameter: 0 or 1

Description: This instruction globally enables or disables the snapshot functionality. Snapshot is globally enabled by default (power-on) in order to support stand-alone applications. Latched key pressed events or the **snsm=6** waiting state of a move is cleared when enabling/disabling the Snapshot (sns0,1).

0 = disabled
1 = enabled (default)

Response: Snapshot state

Examples:
!sns 0 Disable snapshot
!sns 1 Enable snapshot
?sns Read snapshot enable state

23.2. sns1 (Snapshot Level / Polarity)

Syntax: !sns1 or ?sns1
Parameter: 0 or 1

Description: This instruction sets the snapshot input signal polarity.
0 = active low (falling edge)
1 = active high (rising edge)

Response: Currently used snapshot polarity

Examples:
!sns1 0 Set snapshot input to active low
!sns1 1 Set snapshot input to active high
?sns1 Read current snapshot input polarity

23.3. snsf (Snapshot Filter)

Syntax: !snsf or ?snsf
Parameter: 0 to 255 [ms]

Description: This instruction reads or sets the snapshot filter time which is used to debounce the snapshot input signals. The value is in milliseconds, 0 to 255. Debouncing should be used for push-buttons, switches, light barriers etc. A time of 0 disables the filter, which might be necessary for faster, digitally generated signals. Please note that the minimum high and low times of the input signal must be greater or equal to 200µs each in order to be recognized.

Response: Currently used snapshot filter time

Examples:
!snsf 0 Disable input filter
!snsf 10 Set snapshot filter time to 10 ms
?snsf Read snapshot filter time

23.4. snsrm (Snapshot Mode)

Syntax: !snsrm or ?snsrm
Parameter: 0, 1, ... 8

Description: This instruction reads or sets the snapshot mode (default=0).

- 0 = Capture positions to list with Joystick key F2
- 1 = Move forward through position list with Joystick key F2
 (wraps around at the last element)
- 2 = Extended move with Joystick keys:
 - F1: Move backward through position list (wraps around)
 - F2: Move forward through position list (wraps around)
 - F3: Move to '**prehome**' then start of list (first element)
 - F4: Move to '**prehome**' with '**vel**' then '**home**' with '**sevel**'
- 3 = Simple continuous path control in conjunction with
 preloaded **snsa/snse** positions (dissection mode).
 The path travel velocity is set by scanvel.
 Start with Joystick key F2 or corresponding "snse 2".
 HDI must be enabled (by joy, joydir) to provide this
 functionality.
- 4 = Like mode 0, but Snapshot I/O input is used instead of F2
- 5 = Like mode 1, but Snapshot I/O input is used instead of F2
- 6 = Triggered start: Move and Speed instructions will wait
 for the I/O connector snapshot event to start moving.
 Axes must be assigned by the '**snsaxis**' instruction.
- 7 = Custom HDI mode with Prehome, Home and auto increment
 in a time interval set by the '**delay**' instruction.
- 8 = A Trigger-OUT event (not a Snapshot event) captures
 positions and the ANIN0 analogue signal (of the optional
 AUX-I/O connector, available with DT and PCI/PCI-E TANGOs)

Position capture also captures the analog voltage at the AUX-I/O ANIN0 input pin. For controllers that provide this input the captured voltage can be read by sending '**?snsrv**'.

Latched key pressed events or the snsrm=6 waiting state of a move is cleared when setting the Snapshot mode.

Remarks: F1-F4 key events can also be generated by '**snse**' 1 to 4.

A snapshot is always executed on all active axes. Capture and move. For snapshot move the position list must be filled with valid positions for all axes.

Response: Currently selected snapshot mode

Examples:

```
!snsrm 0       Set snapshot mode to capture (with joystick key F2)
!snsrm 1       Set snapshot mode to move (with joystick key F2)
!snsrm 2       Set snapshot mode to extended move
!snsrm 8       Set snapshot mode to capture at trigger out events
?snsrm         Read current snapshot mode
```

23.5. Snapshot Mode Description and Examples

Snapshot Mode 1,2,3,7 move functions, accessible via Joystick F1-F4 keys or !snse 1-4 instruction:

Key	Mode function			
	1	2	3 (DISSECTION)	7 ***
F1 =	-	previous point**	-	prehome & home
F2 =	next point	next point**	start dissection	auto inc from 1st point
F3 =	-	prehome & first point	-	pause/continue
F4 =	-	prehome & home	-	pause & previous point

Remarks: A move to the "prehome" positions always travels at secvel.

Prehome & home means that the axes move to prehome and after reaching directly to home. This is used to avoid possible collisions on the way to the home position.

Prehome & first point means that the axes move to prehome and after reaching directly to the first position in the position list. This sequence is also for collision prevention.

** SnapShot mode 2:

F3 function must be executed in order to enable the F1 and F2 functionality
F4 disables the F1 and F2 functionality, so pressing F3 is required again

*** SnapShot Mode 7:

1. Execute a !cal and !rm instruction to define the repeatable, absolute position (origin).
2. Define the !prehome and the !home positions.
3. Define a position list of points using the !snsa instruction.
4. Specify a user delay between the positions by using the !delay instruction.
5. Enter snapshot mode 7 by sending the !snsm 7 instruction.

All information is lost when the TANGO controller is switched off or reset.

The delay also applies to all move instructions. So when leaving the snapshot mode 7 it is recommended to reset the delay value back to zero (!delay 0).

Snapshot mode 7 uses the joystick keys F1 to F4 according this specification:

- F1 = Go to load/unload position (as defined with the !home and !prehome instructions)
- F2 = Start Auto Movement from Point 1 (through position list, defined by the !snsa instruction and using a delay as defined by the !delay instruction)
- F3 = Pause/Continue from current position (halt the automatic move)
- F4 = Move back one position in the list (when in pause, else it is paused after reaching the next position and then it moves back.)

Instruction sequence example for snsm 7:

```
!cal
!rm
!sns 0
!delay 1000 (delay between moves e.g. 1000ms)
!prehome [Xpos] [Ypos] [Zpos] [Apos] (specify load position)
!home [Xpos] [Ypos] [Zpos] [Apos] (specify unload position)
!snsa 0 (clear the snapshot array / position list)
!snsa 1 [Xpos] [Ypos] [Zpos] [Apos] (load position list)
!snsa 2 ... (load position list) ...
... !snsa N ...
!snsm 7 (enter snapshot mode 7 for F1-F4 functionality)
!sns 1 (activate snapshot function globally)
```

(From TANGO firmware 1.57 autoincrement can be aborted by the abort "a" instruction)

SnapShot Mode 3 (dissection, simple continuous path functionality):

Typical applications are laser dissection or adhesive dosers/dispensers.

Remarks: All axes must be idle and all axis positions must be loaded with valid entries.

The simple continuous path functionality has a continuous increase in position deviation that will build up during the sequence (about 10µm). Interpreter is blocked.

```
!scanvel [mm/s] (set the path/vector velocity)
!sns 0
!snsa 0 (clear the snapshot array / position list)
!snsa 1 [Xpos] [Ypos] [Zpos] [Apos] (load position list)
!snsa 2 ... (load position list) ...
... !snsa N ...
!snsm 3 (enter snapshot dissection mode 3)
!sns 1 (activate snapshot function globally)
!snse 2 (start the dissection sequence, or press F2 key)
?err (send a request and wait for reply --> completed)
```

23.6. snsc (Snapshot Counter)

Syntax: !snsc or ?snsc
Parameter: none, 0 or 1 to 1024 (not greater than the current snsc count)

Description: This instruction reads or sets the snapshot counter, which shows the snapshot array entries (counted snapshot events). This instruction may also be used to reset the counter to zero or reduce the size of an existing array.

Response: Current snapshot array entries (number of snapshot events)

Example:
?snsc Read the number array entries (e.g. captured snapshots)
!snsc Clear snapshot counter to zero elements
!snsc 0 Clear snapshot counter (same as without parameter)
!snsc 50 Reduce snapshot array entries to 50 (only if the current snsc value is equal or higher than the new value)

23.7. snsi (Snapshot Index)

Syntax: !snsi or ?snsi
Parameter: 0 to 1023 (less than the current snsc count)

Description: This instruction reads or sets the snapshot array pointer.

In snapshot modes 1 and 5 this pointer access can be used to manipulate the array index where move target positions are read from.

Opposed to other snapshot instructions the index range here is [0...N-1] instead of [1...N]. The value must be less than the amount of **snsc** array entries.

Remarks: The pointer is only used for the snapshot move. It does not define the array index where positions are written to. Captured positions are always appended as the last element of the array. For array manipulations by software please refer to '**snsa**' and '**snsr**'.

Response: Current snapshot array pointer

Example:
?snsi Read the current array pointer position
!snsi 0 Set array pointer to the first element
!snsi 20 Set array pointer to the 21st element

23.8. snsaxis (Snapshot Axis)

Syntax: !snsaxis or ?snsaxis
Parameter: x, y, z, a or none
 0 or 1

Description: Defines which axes should wait in Snapshot mode 6.
 Please refer to '**snsm**' for further information.
 When sending a moa, mor or speed instruction with sns 6,
 axes can be specified that should not execute the move until
 triggered by a snapshot-in event. This can be used in cases
 where precise start timing has to be controlled by an external
 signal (maybe also set the '**trigf**' value to zero then).

 1 = move or speed of this axis will wait for snapshot signal
 0 = axis does not wait for snapshot signal (default operation)

Remarks: If not all axes are set to waiting mode, a vector move may
 start some of the axes while the others are waiting.
 Such problem does not exist when using single axis move/speed
 instructions.

Response: Wait mode setting of the axes

Example:

```
!snsaxis 1 0 1     Set axis X, Z to waiting mode, Y does not have to wait
!snsaxis y 1       Set axis Y to waiting mode
?snsaxis           Read waiting mode of all available axes (e.g. returns "0 0 0")
?snsaxis z         Read waiting mode of Z axis only (e.g. returns "1")
```

23.9. snsp (Snapshot Position)

Syntax:	!snsp or ?snsp
Parameter:	x, y, z, a or none Positions (unit depends on "dim")
Description:	This instruction reads the most recently captured Snapshot Position. It can also be used to append new positions to the Snapshot position array. The snapshot counter 'snsc' will be incremented automatically. Please also refer to 'snsa'.
Remarks:	The unit of the position data depends on selected 'dim' value. Only motor positions can be read. In order to read captured encoder positions, please refer to '?snsa'.
Response:	Last captured Snapshot position of the specified axis or of all available axes
Examples:	
?snsp	Read last captured snapshot position of all axes
?snsp z	Read last captured snapshot position of Z axis only
!snsp 10 20 30	Append new motor position entry for X, Y and Z axis
!snsp y 2000	Append new position entry with Y-axis only (not recommended)

23.10. snsas (Snapshot Array)

Syntax:	!snsas or ?snsas
Parameter:	x, y, z, a or none -1, 0 or 1 to 1024
Description:	Read, fill, modify or clear the snapshot position array, which may contain up to 1024 elements. For reading a valid element, the index must have a value between 1 and the maximum of the snapshot counter value. Please also refer to '?snsc'. To append new position data to the array, an index of [snsc+1] or index=-1 may be used. The Snapshot counter then will be incremented by 1 automatically. Parameter: -1 = last/append, 0 = clear, 1...1024 = r/w access.
Remarks:	The unit of the position data depends on selected 'dim' value. The read position values are either motor positions or encoder positions, depending on active encoders and 'encpos' settings. Encoder position is only available with captured positions, not when the position entry was written by software (!snsp or !snsas). In this case the encoder position is read as 0 and 'encpos' should be set to 0 for reading this position.
Response:	Snapshot array position(s) in 'dim' units.
Examples:	
?snsas 1	Read all axis positions of the first snapshot entry
?snsas 33	Read all axis positions of the 33rd snapshot entry
?snsas z 99	Read the Z-axis position of the 99th snapshot entry
?snsas y -1	Read the Y-axis position of the last snapshot entry
?snsas -1	Read all axis positions of the last snapshot entry
!snsas 0	Clear the entire snapshot array
!snsas x 1 20.5	Set X position of first element to 20.5 (e.g. mm if dim=2)
!snsas 2 10 10 10 10	Set all axis positions of the second array entry to 10
!snsas -1 10 10 10 10	Append a new entry to the position array (snsc is incremented)

23.11. snse (Snapshot Event)

Syntax: !snse or snse
Parameter: 1, 2, 3 or 4

Description: Executes the F-key Snapshot functions via the communication interface. Instead of pressing a Joystick button or using the AUX-I/O signal, the functions can be triggered by software:

1 = Function normally executed by pressing Joystick F1 key
2 = Function normally executed by pressing Joystick F2 key
or using the AUX-I/O SnapShot input
3 = Function normally executed by pressing Joystick F3 key
4 = Function normally executed by pressing Joystick F4 key

Remark: Behavior is the same as with the function keys. It depends on the snapshot mode settings and only works when Snapshot is enabled. Does not work with Snapshot Mode 8, as this mode requires trigger out signals being generated by the TANGO.

Response: -

Example:
snse 2 Execute F2 Snapshot event (e.g. capture current position to the snapshot position array)

23.12. sns v (Snapshot Voltage)

Syntax: !sns v or ?sns v
Parameter: 1 to 1024 or -1 to -1024

Description: Read the AUX-I/O ANIN0 input voltage (0...5V), captured at the specified position array index. The value can also be written to (i.e. as temporary data storage)
Index > 0: read Voltage in [mV]
Index < 0: read raw ADC data

Remarks: The specified index must be in the range of 1 to +- '**sns c**'. The [mV] values are always calculated with the internal voltage reference, while the raw data is the direct ADC sampling result which may be less accurate (only PCI-E based TANGOs have an accurate ADC sampling result). The raw data range is always 12bit, but with PCI-S based controllers the 2 LSBs are always zero (10bit resolution).

Response: Voltage in [mV] or in [12bit ADC raw data]

Example:
?sns v 2 Read captured Voltage [mV] of 2nd snapshot array entry
?sns v -2 Read captured Voltage [raw] of 2nd snapshot array entry
!sns v 5 1234 Store the value 1234 in 5th snapshot array voltage element

23.13. prehome (Snapshot PreHome Position)

Syntax: !prehome or ?prehome

Parameter: x, y, z, a or none

Description: This instruction sets the prehome position used by the snapshot extended move. The unit of the input position depends on the setting of "dim".

Remarks: Used in snapshot modes (**sns**m) 2 and 7.

Response: Position value(s)

Examples:

!prehome y 10.2 Set prehome position Y-value to 10.2 (e.g. [mm] when dim=2)

!prehome 10 0 20 Set prehome position X,Y,Z

?prehome x Read currently used prehome position of X axis only

?prehome Read currently used prehome positions of all axes

23.14. home (Snapshot Home Position)

Syntax: !home or ?home

Parameter: x, y, z, a or none

Description: This instruction sets the home position used by the snapshot extended move. The unit of the input position depends on the setting of "dim".

Remarks: Used in snapshot modes (**sns**m) 2 and 7.

Response: Position value(s)

Examples:

!home y 10.2 Set home position Y-value to 10.2 (e.g. [mm] when dim=2)

!home 10 0 20 Set home position X,Y,Z

?home x Read currently used home position of X axis only

?home Read currently used home positions of all axes

24. Glossary

AUX I/O	Optional extension connector for PCI-S and PCI-E based TANGOS / TANGO Desktop. Provides analog and digital I/O, safety and trigger functionality.
Cal	Commands axes to travel towards the lower limit switch. Usually the zero position is also set by this instruction.
Closed Loop	The axis position is controlled according to a measuring system.
HDI	Human Device Interface, manual control of the axes, e.g. Joystick.
I/O1	Optional extension module for digital I/O 24xIN + 8xOUT
Multi I/O	Optional I/O extension for digital 12xIN + 8xOUT for 24, 12 or 5V
Rm	Commands axes to travel towards the upper limit switch. Usually executed directly after cal, then it also disables the secvel velocity limitation.
PCI-E	TANGO controller type for PCI-E slots. Offers greater functionality Compared to the PCI-S. Used in TANGO Desktop named DT-E.
PCI-S	TANGO controller type for PCI slots. Also used in TANGO Desktop.
Secvel	Secure velocity which limits the axis travel velocity as long as no cal and rm has been executed. Ment to protect the axes from damage when traveling too fast into the axis hardware limits.
Snapshot	Trigger input functionality, also available with joystick key F2.
TANGO	Motion controller for stepper motors, also called controller.

25. Document Revision History

No.	Revision	Date	Changes	Remarks
01	A	27. March 2012	Newly revised and extended document version	Based on TANGO firmware revision 1.57
02	B	16. April 2012	Added instructions: Ecomove, noled, calrequired, joychangeaxis, ctrsm, ctrs, trigo, trigcomp, trigenc, snsi, snsaxis, sns, zwfactor, detext, posclr, maxaxis, trigbwidth, trigbdelay, trigbf, encrefvel, vrm, flash, etspresent, stagesn Added stop and stoppol modes !joy instruction autostatus behavior	Based on TANGO firmware revision 1.57
03	C	03. May 2012	caldir marked as dummy, naming conventions, version instruction	
04	D	18. July 2012	Remarks concerning closed loop behavior and (current) reduction	
05	-	30. July 2012	digin, digout, diginpol, digintyp, digoutpreset	Based on TANGO firmware revision 1.57
06	Prelim E	06. Sept. 2012	Added: Glossary of common terms, Joystick Key Assignment chart Second Trigger Output description Multi I/O instructions edigin, edigout, ediginpol, edigintyp, edigoutpreset Adapted to naming conventions Improved description of HDI	Based on TANGO firmware revision 1.58
07	E	18. Feb. 2013	Added: anamode, trigr, corrst	Based on TANGO firmware revision 1.60
08	F	25. June 2013	Added I/O communication error 77 ?ver instruction "Ver:" to "Vers:" Improved vrm description	
09	G	23. Aug. 2013	Improved go, speed, vel description	Final documentation of firmware 1.60